



# Information Bulletin Science 30

Diploma Examinations Program **2025–2026**

---

**This document was primarily written for:**

Students

Teachers  of Science 30

Administrators

Parents

General Audiences

Others

---

***2025–2026 Science 30 Information Bulletin***

Distribution: This document is posted on the [Alberta Education and Childcare](#) website.

Copyright © 2025, the Crown in Right of Alberta, as represented by the Minister of Education and Childcare, Alberta Education and Childcare, Provincial Assessment, 6th floor, 44 Capital Boulevard, 10044 108 Street NW, Edmonton, Alberta T5J 5E6, and its licensors. All rights reserved.

**Special permission** is granted to **Alberta educators only** to reproduce, for educational purposes and on a non-profit basis, parts of this document that do **not** contain excerpted material.

Excerpted material in this document **shall not** be reproduced without the written permission of the original publisher (see credits, where applicable).

# Contents

Introduction.....	1
Examination Security.....	2
Time Limits on Diploma Examinations.....	2
Equating to Maintain Consistent Standards over Time on Diploma Examinations .....	3
Diploma Examinations: Multiple Forms .....	4
How to Get Involved.....	5
Field Testing .....	6
· How do field tests help teachers and students?	6
· How are field-test data used?	6
· Science field tests	6
· How can teachers schedule field tests?	7
Science 30 Field Testing.....	8
Practice Tests.....	9
Special-format Practice Tests .....	9
Audio Descriptions .....	9
Course Objectives .....	10
Science 30 Available in French.....	10
Cognitive Expectations in the Program of Studies .....	11
Questions Illustrating Various Cognitive Levels .....	12
Performance Expectations .....	15
· Curriculum standards	15
· Acceptable standard	15
· Standard of excellence	15
Examination Specifications and Design .....	16
<b>Science 30 Diploma Examination</b> Instructions Pages: Paper Format.....	18
<b>Science 30 Diploma Examination</b> Instructions Page: Digital Format.....	22
<b>Science Data Booklet</b> .....	23
Ordering Science 30 Print Resources .....	23
Using Calculators .....	23

<b>Assessment of STS Outcomes .....</b>	<b>24</b>
<b>Assessment of Skills Outcomes .....</b>	<b>25</b>
<b>Trends in Student Performance .....</b>	<b>27</b>
· General strengths of students on past <i>Science 30 Diploma Examinations</i>	27
· General Outcome A1/A2: Circulatory and Immune Systems	27
· General Outcome A3: Genetics	27
· General Outcome B1/B2/B3: Environmental Chemistry	27
· General Outcome C1: Field Theory and Electrical Energy	28
· General Outcome C2: Electromagnetic Spectrum	28
· General Outcome D1/D2: Energy and the Environment	28
<b>Clarifications and Depth of Coverage .....</b>	<b>29</b>
· Unit A, General Outcome 1	30
· Unit A, General Outcome 2	35
· Unit A, General Outcome 3	37
· Unit B, General Outcome 1	48
· Unit B, General Outcome 2	53
· Unit B, General Outcome 3	61
· Unit C, General Outcome 1	63
· Unit C, General Outcome 2	70
· Unit D, General Outcome 1	75
· Unit D, General Outcome 2	78
<b>WHMIS 2015 .....</b>	<b>88</b>
<b>Development of Textbook Resources to Support the Program of Studies .....</b>	<b>89</b>
<b>Publications and Supporting Documents .....</b>	<b>90</b>
<b>Website Links .....</b>	<b>91</b>
<b>Contacts 2025–2026 .....</b>	<b>92</b>

Please note that if you cannot access one of the direct website links referred to in this document, you can find diploma examination-related materials on the [Alberta Education and Childcare](#) website.



## Introduction

The purpose of this bulletin is to provide teachers of Science 30 with information about the diploma examinations scheduled in the 2025–2026 school year. This bulletin should be used in conjunction with the current [Science 30 Program of Studies](#).

This bulletin includes descriptions of the *Science 30 Diploma Examinations* that will be administered in November 2025 and January, April, June, and August 2026; clarifications of some aspects of the examinations; descriptions of trends in student performance on previous examinations; and other subject-specific information.

Diploma exams will be weighted at 30%, and the school-awarded mark will constitute 70% of a student's final mark.

Teachers are encouraged to share the contents of this bulletin with students.

For further information about program implementation, refer to the [Alberta Education and Childcare](#) website.

---

## Examination Security

All diploma examinations will be held secure until they are released to the public by the Minister. No secure diploma examination is to be viewed until it is released to the public by the Minister. No secure diploma examination is to be previewed, discussed, copied, or removed from the room in which the examination is being written. However, for the January and June administrations only, teachers will be allowed access to a teacher perusal copy for review purposes 1 hour after the examination has started.

For mathematics and science diploma examinations, all diploma examinations must be kept secure before, during, and after administration, without exception.

For humanities diploma examinations, the humanities *Part A: Written Response* examinations in the January and June administrations must be kept secure until after they are administered. All other humanities *Part A: Written Response* examinations, and all humanities *Part B* examinations, must be kept secure before, during, and after administration, without exception.

Unused copies of all secured diploma examinations must be returned to Alberta Education and Childcare as per the dates indicated in the [Significant Dates at-a-Glance](#) resource.

For more information about teacher perusal copies and examination security, please refer to the [Administering diploma exams](#) web page.

---

## Time Limits on Diploma Examinations

All students may use extra time to write diploma examinations. This means that all students have up to 6 hours to complete the *Science 30 Diploma Examination*, if they need it. The examination is nevertheless designed so that the majority of students can complete it within 3 hours. The examination instructions state both the designed time and the total time allowed.

Although extra time is allowed for diploma examinations in all subjects, the total time allowed is not the same in all subjects. For more information about accommodations and provisions for students, please refer to the [Administering diploma exams](#) web page.



## Equating to Maintain Consistent Standards over Time on Diploma Examinations

A goal of Alberta Education and Childcare is to make scores achieved on examinations within the same subject directly comparable from session to session, to ensure fairness to students across administrations.

To achieve this goal, the examination has a number of questions in common with a previous examination. Common (anchor) items are used to find out if the student population writing in one administration differs in achievement from the student population writing in another administration. Common items are also used to find out if the unique items (questions that have never appeared in a previous examination) differ in difficulty from the unique (non-anchor) items on the baseline examination that sets the standard to which all students are held.

A statistical process called equating adjusts for differences in difficulty between examinations. Examination marks may be adjusted depending upon the difficulty of the examination written relative to the baseline examination. Therefore, the resulting equated examination scores have the same meaning regardless of when and to whom the examination was administered. Equated diploma examination marks are reported to students. More information about equating is available on the [Administering diploma exams](#) web page.

Because of the security required to ensure fair and appropriate assessment of student achievement over time, *Science 30 Diploma Examinations* will be fully secured and will not be released at the time of writing.



## Diploma Examinations: Multiple Forms

Some subjects may have two distinct forms (versions) of diploma examinations during major administrations (January and June). Like all other diploma examinations, the two forms are equated to the baseline examination to ensure that the same standard applies to both forms. Both forms adhere to the established blueprint specifications and are reviewed by a technical review committee.

To facilitate the analysis of school-level results, each school receives only one examination form per subject. In subjects offering a translated French-language examination, both forms are administered in English and in French.

### **For more information, contact the following:**

Diploma exam format, content, confirming standards,  
marking, and results reporting

[Diploma.Exams@gov.ab.ca](mailto:Diploma.Exams@gov.ab.ca)

or

French Assessment

[French.Assessment@gov.ab.ca](mailto:French.Assessment@gov.ab.ca)

or

Diploma exam security, diploma exam rules,  
scheduling, and policy issues

[Exam.Admin@gov.ab.ca](mailto:Exam.Admin@gov.ab.ca)



## How to Get Involved

High-quality diploma examinations are the product of close collaboration between classroom teachers and Alberta Education and Childcare. Classroom teachers from across Alberta are involved in many aspects of diploma examination development, including the development of items; the building, reviewing, administering, and marking of field tests; the reviewing and validating of diploma examinations; the reviewing of support documents; and the marking of diploma examinations.

The development of test items from when they are written until when they appear on an examination takes at least one year. All items on the *Science 30 Diploma Examinations* are written and/or validated by Science 30 teachers from across Alberta. After provincial implementation of the program of studies, items are field tested to ensure their reliability and validity. Diploma examinations are reviewed by editors, teachers, academic experts, curriculum staff, translators, and a French validation working group.

Alberta Education and Childcare values the involvement of teachers and annually asks school authorities for the names of teachers who are interested in being involved in any of the development processes for diploma examinations. Teachers who are interested in developing items, constructing field tests, or reviewing and validating examinations are encouraged to talk to their principals about how they can submit their names for approval to be involved in these processes. Although the call for submissions for working groups occurs each fall, teachers are welcome to have their names submitted at any time.

## Field Testing

Field testing is an essential stage in the development of fair, valid, and reliable provincial examinations. Field testing is a process of collecting data on questions before the questions become part of a diploma examination. Potential diploma examination questions are administered to students in field tests for diploma courses throughout the province to determine the difficulty and appropriateness of the questions. Each field test requires a large student sample to provide the examination developers with reliable information (i.e., statistical data and written validation comments from teachers and students).

### How do field tests help teachers and students?

Teachers receive each student's score promptly, gaining useful information about their students' performance. Students benefit from writing a test that duplicates some of the experience of writing a diploma examination. Field tests provide students and teachers with examples of the format and content of questions that may appear on diploma examinations. Finally, because of field testing, students, teachers, and parents can be reassured that the questions on diploma examinations have undergone a rigorous development, improvement, and validation process.

### How are field-test data used?

The data received from field tests indicate the validity, reliability, and fairness of each question. Questions that meet specific standards are selected for use on future diploma examinations.

Some questions or sets of questions may not initially perform as well as we require. These questions may be revised and tested again in field tests. Revisions are influenced by the written comments of students and teachers, who provide valuable advice about the appropriateness of the questions, the adequacy of writing-time limits, test length, text readability, artwork/graphics clarity and suitability, and question difficulty.

### Science field tests

Science field tests are available in digital format on the digital assessment platform.

Students may use paper data booklets or data pages for all science field tests. These resources will also appear in the digital assessment platform. Students should have scrap paper, which may be accessed in the "Forms" section on the [Administering diploma exams](#) web page. All paper data sheets and scrap paper with markings must be securely shredded at the end of the field-test administration.

Teachers are provided with data on how their students performed. Test items address learning outcomes in the program of studies, which allows teachers to use field-test results to learn more about their students' strengths and areas for improvement.

The security of field-test items remains vital to the administration of diploma examinations. Participating teachers must commit to maintaining the security of field-test items.

More information about field-test registration deadlines, administration, and security is available in the *Field Testing Guide 2025–2026* on the [Teacher participation in provincial assessments](#) web page.

## How can teachers schedule field tests?

Field tests are offered digitally on the digital assessment platform. To schedule a field test, teachers must have a digital assessment platform teacher account.

For information about how to schedule and administer a field test, please refer to the *Field Testing Guide 2025–2026* on the [Teacher participation in provincial assessments](#) web page or contact [Field.Test@gov.ab.ca](mailto:Field.Test@gov.ab.ca).

Detailed instructions for how to schedule a field test can also be found on the digital assessment platform [Help](#) web page.

### **For more information, contact the following:**

Diploma exam format, content, confirming standards,  
marking, and results reporting  
[Diploma.Exams@gov.ab.ca](mailto:Diploma.Exams@gov.ab.ca)

or

French Assessment  
[French.Assessment@gov.ab.ca](mailto:French.Assessment@gov.ab.ca)

or

Diploma exam security, diploma exam rules,  
scheduling, and policy issues  
[Exam.Admin@gov.ab.ca](mailto:Exam.Admin@gov.ab.ca)

## Science 30 Field Testing

An end-of-course field test and four unit tests are offered in digital format for the 2025-2026 school year. Each field test is designed to take 65 minutes of writing time and has approximately 25 to 30 questions. (Students are allowed an extra 15 minutes of writing time, if it is available.)

---

Type of Field Test	
Unit test (online)	Unit A
	Unit B
	Unit C
	Unit D
End-of-course (online)	All units

---

\*For all field tests, students are allowed an extra 15 minutes of writing time, if it is available.

---

The data booklet is available in the digital assessment platform for Science 30 field tests; however, students are still permitted to use paper copies of the data booklet when writing field tests, and teachers should ensure that their class has sufficient unmarked data booklets available for the testing session. For all field tests, an additional 10 minutes of administration time is required for each field-test administration period. Therefore, a class in which a Science 30 field test is to be administered should be a minimum of 75 minutes.

If your class periods are shorter than 75 minutes, but you would like your students to participate in field testing, you can still request a field test if arrangements can be made in the school to provide students with an appropriate time for the field test.

Field tests can be scheduled either within class time or outside of class time up to the day before the *Science 30 Diploma Examination*.

For information about how to schedule and administer a field test, please refer to the *Field Testing Guide 2025–2026* on the [Teacher participation in provincial assessments](#) web page or contact [Field.Test@gov.ab.ca](mailto:Field.Test@gov.ab.ca).

---

## Practice Tests

To give students an opportunity to practise answering questions similar to those used on diploma examinations that address learning outcomes in the program of studies, Alberta Education and Childcare produces practice tests for subjects that have a diploma examination. Students can access these practice tests using Alberta Education and Childcare's [digital assessment platform](#).

---

## Special-format Practice Tests

To give students an opportunity to practise answering questions similar to those used on diploma examinations that address learning outcomes in the program of studies in Braille, large print, or coloured print versions, Alberta Education and Childcare produces special-format practice tests for all subjects that have a diploma examination. Alberta schools with registered Alberta K–12 students may place orders for these tests. Braille versions are available in English and, by request, in French. All tests are provided free of charge, but limits may be placed on order volumes to ensure access for all students.

For the greatest benefit, special-format practice tests should be written under conditions similar to those of the corresponding diploma examination. The same rules regarding the use of resources and devices should be followed.

Braille versions must be returned to Alberta Education and Childcare after use.

For more information or to place an order, contact [Field.Test@gov.ab.ca](mailto:Field.Test@gov.ab.ca).

---

## Audio Descriptions

A support document, [Examples of Descriptions Used in Audio Versions of Science Diploma Exams](#), has been developed to assist teachers and students planning to use an audio version during the administration of a science diploma examination.

---

## Course Objectives

Science 30 is designed for students who want to enhance their understanding of the scientific principles behind the natural events in their world and the technology that students use in their daily lives. Science 30 is an inquiry-based course designed to provide students with the scientific literacy required to function in a technological society and to prepare students for post-secondary studies.

Students of Science 30 will develop skills including observing, collecting data, forming generalizations, hypothesizing, and making inferences from observations. They will show growth in their understanding of scientific concepts by their ability to apply these concepts to relevant situations. They will develop a global view of science disciplines as well as an awareness of the connections between those science disciplines.

Experience in science courses, particularly Science 10 and Science 20, enables students to develop the knowledge, skills, and attitudes that facilitate success in Science 30. The *Guide to Education* states that “Students who have achieved a final mark of 50% or greater in any one of Biology 20, Chemistry 20, Physics 20 or Science 20 may enrol in Science 30.”

---

## Science 30 Available in French

The Science 20–30 Program of Studies (French) has been available for implementation in Alberta schools since 2015–2016. The *Science 30 Diploma Examination* has been offered in French in all administrations since the 2020–21 school year.

# Cognitive Expectations in the Program of Studies

Outcomes in the Science 30 Program of Studies contain verbs that indicate the cognitive expectations of the outcome. Verbs typically classified as remembering and understanding (R/U) are coded yellow in the chart below; verbs typically classified as applying (A) are coded green; verbs typically classified as higher mental activities (HMA) are coded blue; and those relating to skills are coded pink.

The following graphic shows the information arranged in a hierarchy, which is the arrangement used in the revised Bloom's taxonomy. The graphic is used fairly consistently in the four diploma examinations that assess science: Biology 30, Chemistry 30, Physics 30, and Science 30.

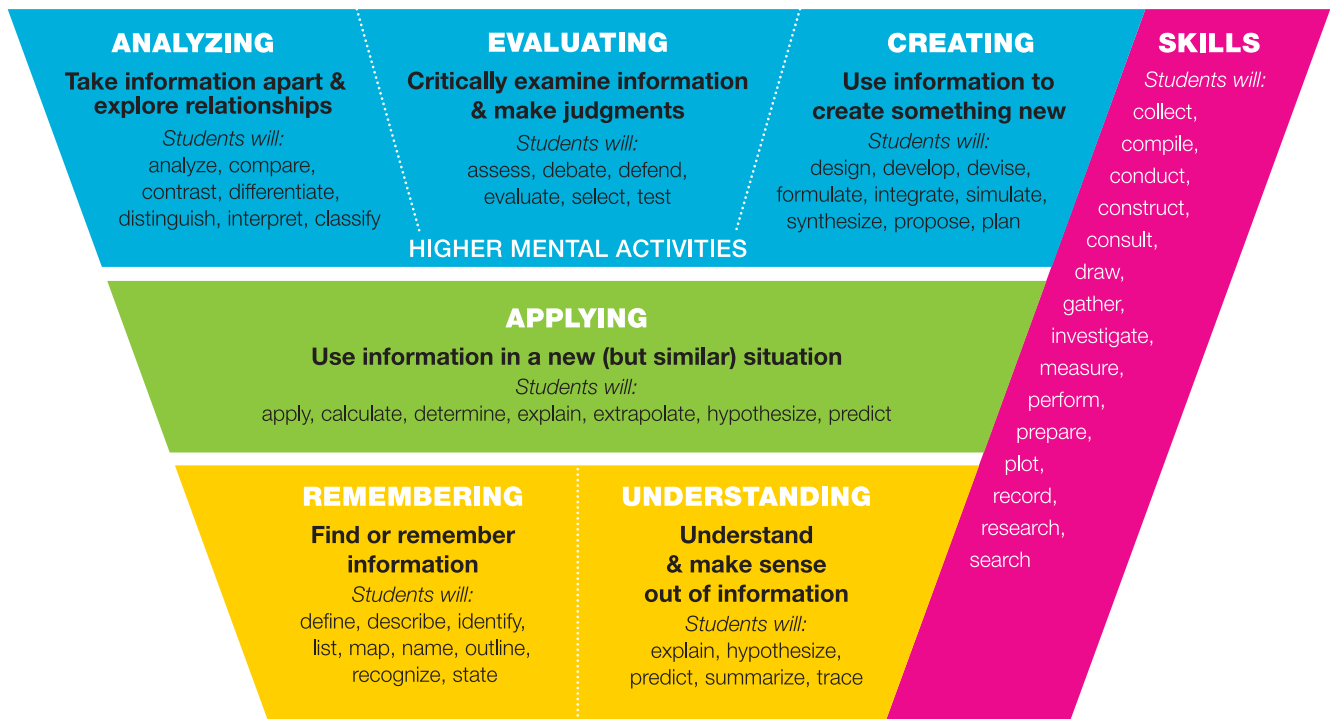

\*Verbs can have multiple connotations and can therefore indicate more than one cognitive level. The cognitive expectation is communicated by the context. —based on Anderson, Krathwohl, and Bloom, 2001.

The verbs arranged in the graphic shown above are only those that have been used in the Science 30 Program of Studies. Remember that the graphic should serve only as a guideline and that the verbs are not permanently fixed in the categories shown. A verb can indicate a variety of cognitive levels depending on the context in which it is used; the verb and the context together are what determines the cognitive expectation.

Note that difficulty is independent of cognitive level. Outcomes at any of the cognitive levels can be assessed at either the acceptable standard or the standard of excellence.

## Questions Illustrating Various Cognitive Levels

This group of three items shows how outcome C1.11k can be tested at a remembering and understanding level (R/U), an application level (A), and a higher mental activity level (HMA).

### Remembering and Understanding (R/U) Level

1. Which of the following devices transforms kinetic energy into electrical energy?
  - A. A DC generator
  - B. A transformer
  - C. A DC motor
  - D. A resistor

The answer is A. Assessing C1.11k

**Applying (A) Level**

*Use the following information to answer question 2.*

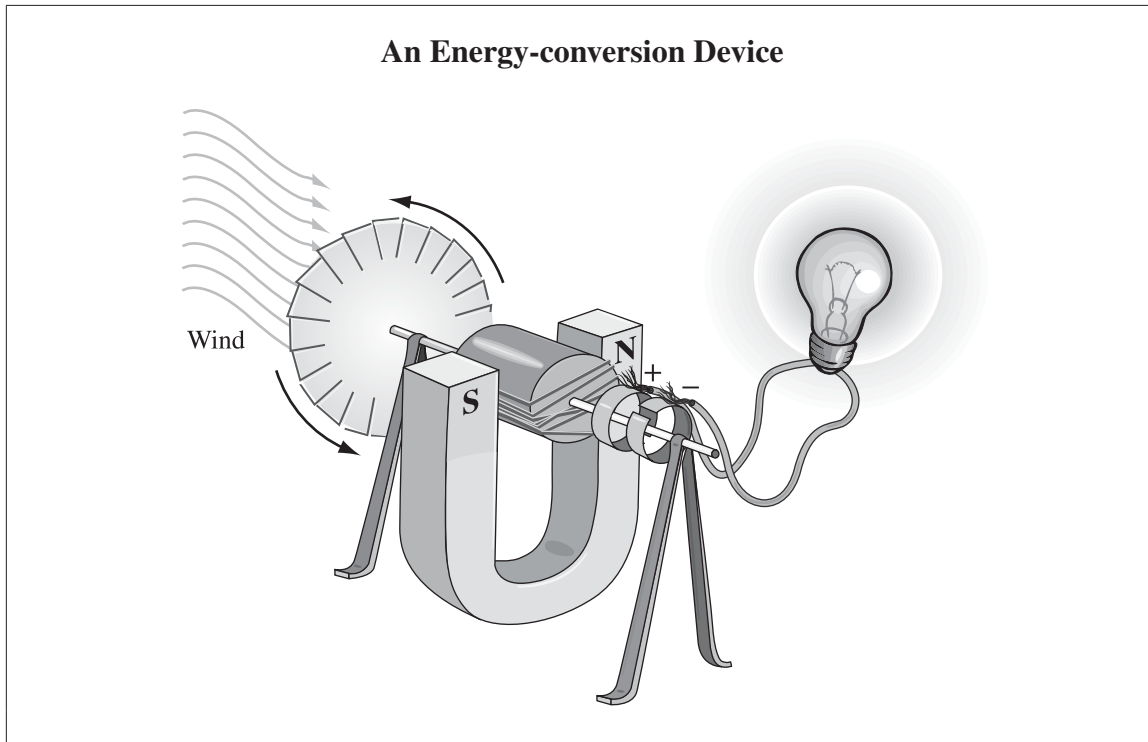

2. The device shown above is
- A. a motor
  - B. a generator
  - C. an ammeter
  - D. a transformer

The answer is B. Assessing C1.11k

Higher Mental Activities (HMA) Level

Use the following information to answer question 3.

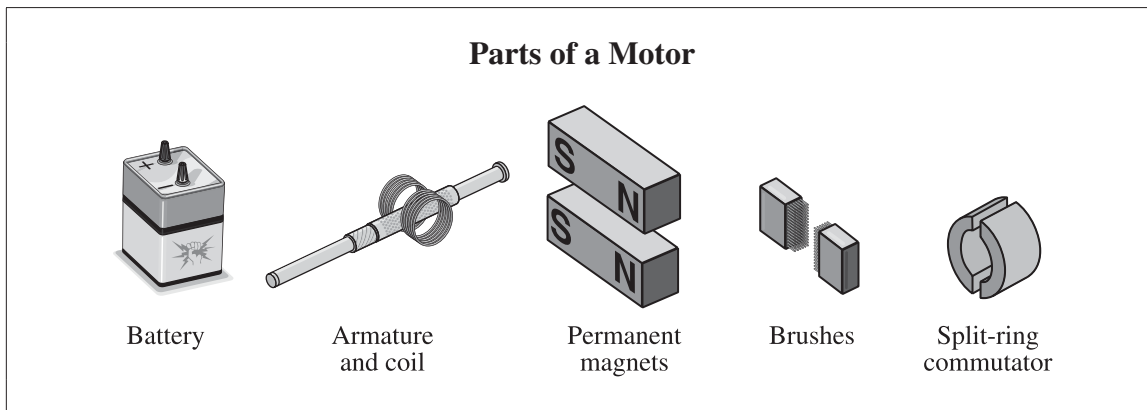

3. Which of the following designs would produce a working motor?

A.

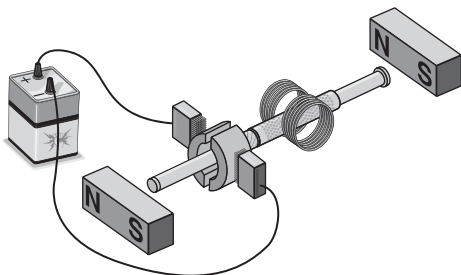

B.

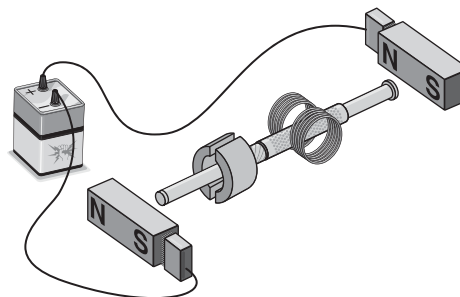

C.

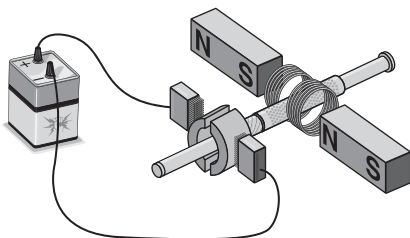

D.

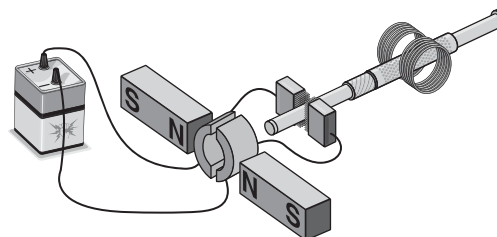

The answer is C. Assessing C1.11k, C1.2s, and C1.3s

# Performance Expectations

## Curriculum standards

Provincial standards help to communicate the level at which students need to perform to achieve the learning outcomes specified for Science 30. Student learning outcomes refer to specific knowledge, skill, and attitude expectations; the science programs of study describe these expectations. The Science 10, 20, and 30 programs of study are available online.

Details regarding learning outcomes are outlined in the Depth of Coverage section of this bulletin. The Depth of Coverage section is intended to describe the extent to which students must demonstrate the Science 30 learning outcomes in order to meet the standards of the [Science 30 Program of Studies](#) and diploma examination.

Diploma exams are designed to match the program of studies of each subject, but what the diploma exams measure may not be the same in scope as what teachers measure. Diploma exam marks and teacher-awarded marks should reflect the same standard, however, because both assess students based on the same program of studies (curriculum). Alberta Education and Childcare works with teachers to set and maintain the standards of achievement for diploma exams. This information bulletin is intended to assist teachers in understanding the provincial standards for Science 30.

## Acceptable standard

Students who achieve the acceptable standard in Science 30 receive a final course mark of 50% or higher. These students state or solve single-step problems and correctly answer questions involving concepts from specified areas of science. These students follow correct laboratory procedures when given specific directions. When presented with data, they can make connections to the scientific concepts and laboratory activities taught in class. These students produce graphs of data from experiments and read values from provided graphs. They use Information and Communication Technology (ICT) skills to gather, manipulate, and communicate information. They use their scientific knowledge to explain the operation and significance of the technologies studied in Science 30. They present arguments about societal issues such as environmental and ethical concerns related to Science 30 content.

## Standard of excellence

Students who achieve the standard of excellence in Science 30 receive a final course mark of 80% or higher. They demonstrate their knowledge, ability, and literacy in a broad range of science areas. These students integrate concepts from many areas of science. They demonstrate creativity and flexibility in solving multistep problems. They design or refine laboratory procedures to investigate scientific principles or solve scientific problems. They use ICT skills to gather, manipulate, and communicate effectively. They critically analyze scientific studies, including charts, graphs, and conclusions. These students are aware of the variety of viewpoints related to environmental and ethical issues in the fields of science and technology and can evaluate technologies and problems from multiple viewpoints. They clearly express their informed opinions regarding these issues.

For more details on the relationship between the program of studies and the performance standards, see the [Science 30 Student-based Performance Standards](#), which provides examples of behaviours exhibited by students at the acceptable standard and at the standard of excellence for the course. It should be used in conjunction with the program of studies, as it is not intended to replace the program of studies.

## Examination Specifications and Design

Each *Science 30 Diploma Examination* is designed to assess the Science 30 general outcomes (GOs) outlined in the [Science 20–30 Program of Studies](#). The GOs are described in more detail by the specific outcomes (SOs), which are organized into the following categories: Outcomes for Knowledge (K); Outcomes for Science, Technology and Society (STS); and Outcomes for Skills (S). Examination questions may be organized into sets that relate to broad contexts. Therefore, a set of questions may assess several GOs.

The *Science 30 Diploma Examinations* are constructed to place the following approximate emphases on the Science 30 GOs.

General Outcomes	Areas of Study	Emphasis
<b>A1 and A2</b>	Analyze the function of the circulatory and immune systems in maintaining human health	<b>10–15%</b>
<b>A3</b>	Apply the principles of heredity and molecular genetics to human diseases and technological applications	<b>10–15%</b>
<b>B1, B2, and B3</b>	Analyze the risks and benefits of the production and use of acids, bases, organic compounds, and chemical technologies	<b>20–30%</b>
<b>C1</b>	Explain and analyze the applications of field theory used to produce and transform electrical energy	<b>13–18%</b>
<b>C2</b>	Describe the properties and applications of electromagnetic radiation in medical technologies, communication systems, and the study of the universe	<b>7–12%</b>
<b>D1 and D2</b>	Explain the origin and use of conventional and alternative energy technologies and the need to maintain a viable biosphere	<b>20–30%</b>

The paper format of the *Science 30 Diploma Examination* consists of 39 multiple-choice and 16 numerical-response questions worth 1 mark each. The digital format of the *Science 30 Diploma Examination* consists of 55 machine-scored questions worth 1 mark each of various types, including multiple-choice questions, supported by the new digital assessment platform.

Questions on the diploma examination will require students to demonstrate knowledge of science concepts and to apply skills in a context that supports making science, technology, and society (STS) connections.

<b>Scientific Process and Communication Skills</b>	<b>Science, Technology, and Society Connections (STS)</b>
<p>Students can</p> <ul style="list-style-type: none"> <li>• design, interpret, explain, analyze, and evaluate investigations</li> <li>• organize data into tables, graphs, and diagrams</li> <li>• predict relationships</li> <li>• interpret, explain, analyze, and evaluate data to infer relationships</li> <li>• use appropriate scientific terminology and mathematical language</li> <li>• to communicate and explain scientific concepts</li> </ul>	<p>The student can</p> <ul style="list-style-type: none"> <li>• apply cause-and-effect reasoning to formulate relationships in which scientific evidence shapes or refutes a theory, and explain the limitations of science and technology in answering all questions and solving all problems</li> <li>• describe and evaluate the design and function of technological solutions to practical problems by using scientific principles and theories, and relate the ways in which science and technology advance each other</li> <li>• evaluate from a variety of perspectives how science and technology are influenced and supported by society and assess the ability of society to interact responsibly with the environment</li> <li>• apply the skills and knowledge acquired in Science 30 to everyday life and to both related and new concepts in post-secondary studies</li> </ul>

Questions may be either discrete or context dependent. A discrete question does not include additional directions or information. The question stem may take the form of a question or an incomplete statement. A context-dependent, or source-based, question provides additional information that may be new to the student. Most questions on the *Science 30 Diploma Examination* are context dependent.

A particular context may be used for more than one machine-scored question.

In addition to answering multiple-choice questions, students may be asked to calculate and enter numerical values; select and/or match events, structures, or functions from a diagram or list; determine and order the sequence of listed events; and rank a group of items according to given criteria.

# Science 30 Diploma Examination Instructions Pages: Paper Format

Copyright © 2026, the Crown in Right of Alberta, as represented by the Minister of Education and Childcare, Alberta Education and Childcare, Provincial Assessment Sector, 6th floor, 44 Capital Boulevard, 10044 108 Street NW, Edmonton, Alberta T5J 5E6, and its licensors. All rights reserved.

Duplication of this examination in any manner or its use for purposes other than those authorized and scheduled by Alberta Education and Childcare is strictly prohibited.

The personal information collected through the Diploma Examinations Program is for the purpose of administering the program as well as support programs, policy evaluation, and measurement. This collection is authorized by section 4(c) of the *Protection of Privacy Act*. For questions about the collection of personal information, contact the Director, Diploma Programs, Provincial Assessment Sector, System Excellence, by email at [Diploma.Exams@gov.ab.ca](mailto:Diploma.Exams@gov.ab.ca) or by mail to 6th floor, 44 Capital Boulevard, 10044 108 Street NW, Edmonton, Alberta T5J 5E6.

## Science 30 Grade 12 Diploma Examination

### Description

**Time: 3 hours.** This closed-book examination was developed to be completed in 3 hours; however, you may take up to 6 hours to complete the examination, should you need it.

This examination consists of 39 multiple-choice and 16 numerical-response questions, of equal value.

This examination contains sets of related questions. A set of questions may contain multiple-choice and/or numerical-response questions.

A science data booklet is provided for your reference.

### Instructions

- Turn to the last page of the examination booklet. Carefully fold and tear out the machine-scored answer sheet along the perforation.

**Note:** Additional tear-out pages at the back of this booklet may be used for your rough work. **No marks** will be given for work done on the tear-out pages.

- Use **only** an **HB** pencil for the answer sheet.
- Fill in the information on the back cover of the examination booklet and the answer sheet as directed by the presiding examiner.
- You may use **one** approved calculator: **either** a scientific calculator that does not have prohibited properties **or** a graphing calculator approved by Alberta Education and Childcare.
- You **must** have cleared your calculator of all information that is stored in the programmable or parametric memory.
- You may use a ruler and a protractor.
- Read each question carefully.
- Consider all numbers used in the examination to be the result of a measurement or an observation.
- When performing calculations, use the values of the constants provided in the data booklet.
- If you wish to change an answer, erase **all** traces of your first answer.
- Do **not** fold the answer sheet.
- The presiding examiner will collect your answer sheet and examination booklet and send them to Alberta Education and Childcare.
- Now read the detailed instructions for answering machine-scored questions.



### Sequencing Question and Solution

#### Four Subjects

- 1 Physics
- 2 Biology
- 3 Science
- 4 Chemistry

When the subjects above are arranged in alphabetical order, their order is \_\_\_\_, \_\_\_\_, \_\_\_\_, and \_\_\_\_.

(Record all **four digits** of your answer in the numerical-response section on the answer sheet.)

Answer: **2413**

Record 2413 on the answer sheet →

2	4	1	3
---	---	---	---

Fill in the corresponding circles

	0	0	0	0
	1	1	1	1
	2	2	2	2
	3	3	3	3
	4	4	4	4
	5	5	5	5
	6	6	6	6
	7	7	7	7
	8	8	8	8
	9	9	9	9

### Selection Question and Solution

#### Five Subjects

- 1 Art
- 2 Music
- 3 Physics
- 4 Biology
- 5 Chemistry

The science subjects in the list above are numbered \_\_\_\_, \_\_\_\_, and \_\_\_\_.

(Record all **three digits** of your answer in any order in the numerical-response section on the answer sheet.)

Answer: **345**

Record 345 on the answer sheet →

3	4	5
---	---	---

Fill in the corresponding circles

	0	0	0	0
	1	1	1	1
	2	2	2	2
	3	3	3	3
	4	4	4	4
	5	5	5	5
	6	6	6	6
	7	7	7	7
	8	8	8	8
	9	9	9	9

**Note:** All answers containing only the three digits 3, 4, and 5, in any order, will be scored as correct.

### Scientific-notation Question and Solution

The speed of EMR in a vacuum, expressed in scientific notation, is  $a.bc \times 10^d$  m/s. The values of  $a$ ,  $b$ ,  $c$ , and  $d$  are  $\frac{\quad}{a}$ ,  $\frac{\quad}{b}$ ,  $\frac{\quad}{c}$ , and  $\frac{\quad}{d}$ .

(Record all **four digits** of your answer in the numerical-response section on the answer sheet.)

Answer:  $3.00 \times 10^8$  m/s

Record 3008 on the answer sheet

3	0	0	8
---	---	---	---

Fill in the corresponding circles

	0	0	0	0
1	1	1	1	1
2	2	2	2	2
3	3	3	3	3
4	4	4	4	4
5	5	5	5	5
6	6	6	6	6
7	7	7	7	7
8	8	8	8	8
9	9	9	9	9

### Multiple-answer Matching Question and Solution

Continent	Country	Capital City
1 North America	4 France	7 Beijing
2 Europe	5 China	8 Ottawa
3 Asia	6 Canada	9 Paris

Using the numbers above, choose **one continent** and match it with a country in that continent and with that country's capital city. (There is more than one correct answer.)

Number: \_\_\_\_\_  
                   Continent           Country           Capital city

(Record all **three digits** of your answer in the numerical-response section on the answer sheet.)

Answer: 168 or 249 or 357

Record 168 on the answer sheet

1	6	8
---	---	---

Fill in the corresponding circles

	0	0	0	0
1	1	1	1	1
2	2	2	2	2
3	3	3	3	3
4	4	4	4	4
5	5	5	5	5
6	6	6	6	6
7	7	7	7	7
8	8	8	8	8
9	9	9	9	9

**Note:** The answers 168, 249, or 357 will be scored as correct.

# Science 30 Diploma Examination Instructions Page: Digital Format

## Science 30

### Grade 12 Diploma Examination

#### Description

**Time: 3 hours.** This closed-book examination was developed to be completed in 3 hours; however, you may take an additional 3 hours, should you need it.

This examination consists of 55 questions, each worth 1 mark.

Data sheets can be viewed by clicking the Resources icon  at the right side of the screen.

A paper version of the data sheets is also permitted.

#### Instructions

- You may use **one** approved calculator: **either** a scientific calculator that does **not** have prohibited properties **or** a graphing calculator approved by Alberta Education and Childcare.
- You **must** clear your calculator of all information that is stored in the programmable or parametric memory both before and after the examination.
- You are permitted to use scrap paper for your rough work. **No marks** will be given for work done on scrap paper.
- When necessary, use the values of constants provided on the data sheets or in the information included with the question.
- If you change an answer, your examination will be automatically updated.
- To submit your **final** answers, click “Submit” on the left side of the screen.

---

## Science Data Booklet

The [Science Data Booklet](#) currently being used will have “Updated 2010” on the cover. It is posted on the [Writing diploma exams](#) web page. Permission is granted to Alberta educators to reproduce the data booklet for educational purposes and on a non-profit basis. Students are permitted to use the print version of the *Science Data Booklet* on both paper-format and digital-format diploma exams.

---

## Ordering Science 30 Print Resources

Print copies of the *Science Data Booklet* and the Science 30 textbook are available from [Alberta King's Printer](#). Search by title or keyword within the online catalogue. Visa, MasterCard, and American Express are accepted. Many schools will already have an account with Alberta King's Printer and can use this account to make a purchase order. Shipping charges will apply and orders can be shipped collect or on account with designated couriers.

---

## Using Calculators

The *Science 30 Diploma Examination* requires the use of a calculator that does not have prohibited properties or a graphing calculator approved by Alberta Education and Childcare. The calculator rules, list of prohibited properties, criteria, and keystrokes for clearing approved graphing calculators are found in *2025–26 Calculator Information and Rules for Mathematics and Science Diploma Exams* on the [Writing diploma exams](#) web page.

Teachers should be aware of the capabilities of approved graphing calculators that are available when the calculator is not configured for exam purposes, as these capabilities may impact classroom instruction and assessment. These capabilities may also be applicable to other high school math and science courses.

## Assessment of STS Outcomes

Examination questions assess students' understanding of concepts in the program of studies. Some questions have been designed to assess students' understanding of the interrelationships between science and technology, as well as between science, technology, and society. Some STS outcomes are not as easily assessed on a machine-scored examination as others. The assumption is made that teachers are carrying out assessments and observations of STS outcomes with their students throughout the course. The appearance of questions on the diploma examination that assess STS outcomes should be expected.

STS-based questions present a problem that requires students to make connections between scientific concepts, technology, and social issues. STS-based questions often assess more than one outcome.

### Sample Question

*Use the following information to answer numerical-response question 1.*

#### Some Arguments Concerning Biomass Fuels

- 1 Farming can have negative impacts on ecosystems, including soil depletion and contamination of water systems with pesticides.
- 2 Using supplies of corn, wheat, and other crops to produce biomass fuels may cause the cost of food to increase.
- 3 Growing crops to produce biomass fuels will help farming industries, encouraging more traditional ways of life.
- 4 Governments should require farmers to grow crops that are used to produce biomass fuels.

### Numerical Response

1. Match each of the arguments numbered above with the perspective listed below that **most accurately** describes the argument. (Use each number only once.)

Political \_\_\_\_\_ (Record in the **first** column)

Economic \_\_\_\_\_ (Record in the **second** column)

Societal \_\_\_\_\_ (Record in the **third** column)

Environmental \_\_\_\_\_ (Record in the **fourth** column)

(Record your answer in the numerical-response section on the answer sheet.)

The answer is 4231. Assessing D1.5k, D2.4k, and D2.1sts



## Assessment of Skills Outcomes

Skill-based questions present a problem that requires students to apply techniques and procedures developed during scientific inquiry. These questions may include descriptions of laboratory procedures or research for students to analyze or evaluate. Data may be provided in the form of graphs and/or tables. Students may be asked to identify the variables or limitations of a study or to identify a study that would be most appropriate to address a particular situation.

Students are expected to communicate using appropriate conventions of science. These conventions include

- graphs, diagrams, and tables
- mathematical formulas and chemical equations
- significant digits, units of measurement, and unit conversions

Some skills outcomes are not as easily assessed on a machine-scored examination as others. The development of skills outcomes is mandated by the program of studies, and, therefore, the appearance of questions on the diploma examination that assess these skills should be expected. Teachers are encouraged to consult the program of studies for a complete description of skills outcomes.

### Sample Question

Use the following information to answer numerical-response question 3.

To determine the effect of acid deposition on corn plants, a solution with a pH of 4.3 was used to water a plot of two-month-old corn plants. More corn plants were grown on another plot under similar conditions but were watered with distilled water that had a pH of 7.0.

#### Experimental Variables

- 1 Type of soil
- 2 Light exposure
- 3 Growth of plant
- 4 Substance used to water plants

### Numerical Response

3. Using the numbers above, identify the manipulated variable, responding variable, and two variables that should be controlled in the experiment. (There is more than one correct answer.)

**Number:** \_\_\_\_\_  
**Variable:**    **Manipulated**            **Responding**            **Controlled**            **Controlled**

(Record all **four digits** of your answer in the numerical-response section on the answer sheet.)

The answer is 4312 or 4321. Assessing B1.1s and B1.2s

## Trends in Student Performance

This section is intended to provide classroom teachers with information concerning student strengths and weaknesses as demonstrated on past *Science 30 Diploma Examinations*. These are trends in student performance as indicated by statistical analyses of the machine-scored examinations.

### **General strengths of students on past *Science 30 Diploma Examinations***

Students do well on questions that incorporate generic science skills, such as interpreting information from a graph or identifying the manipulated, responding, and controlled variables based on descriptions of experiments. They are proficient at carrying out single-step calculations using formulas included in the data booklet.

### **General Outcome A1/A2: Circulatory and Immune Systems**

Students are proficient at identifying the parts of the heart and the roles of the four major blood components but have difficulty applying this knowledge to contexts involving a disease or disorder affecting the circulatory system. Students have difficulty relating blood pressure to the flow of blood in blood vessels; there is a misconception that blood pressure is lowest in the capillaries and that pressure increases as it leaves the capillaries. Questions regarding the specific roles of immune-system cells are typically easy for students, but students find questions requiring them to order steps of the immune response or identify a description of an autoimmune disease more challenging.

### **General Outcome A3: Genetics**

Most students can interpret a description of a genetic trait or construct a Punnett square to identify phenotypes and calculate the probability of inheriting a disorder. Students struggle when interpreting pedigree charts and when differentiating between genetic engineering and gene therapy.

### **General Outcome B1/B2/B3: Environmental Chemistry**

Students do well at predicting the colours of various indicators when the indicators are added to solutions of a given pH and at placing acids in order of strength. Many students are able to calculate the concentration of hydronium ions when given the pH of a solution, but most struggle with calculations involving titrations. Students are easily able to name simple organic compounds when given structural diagrams of the compounds. Students have difficulty distinguishing between the issue of ozone depletion and other environmental issues such as climate change, acid deposition, and biomagnification.

### **General Outcome C1: Field Theory and Electrical Energy**

Most students are able to perform calculations related to Ohm's law, power, and transformers, with the exception of transformer problems involving current. They have difficulty understanding the relationship between field strength and the distance from a source. For example, a very difficult conceptual question would be recognizing that doubling the distance from a particular source would decrease the magnitude of the field strength to one quarter. Students also typically struggle with defining electrical terms, particularly voltage; understanding or applying analogies for circuits; and comparing energy conversions in motors and generators. Students have difficulty demonstrating an understanding of electromagnetic induction.

### **General Outcome C2: Electromagnetic Spectrum**

Students do well at identifying the type of electromagnetic radiation (EMR) from a description of its properties and at performing EMR calculations involving the universal wave equation. They struggle when asked to identify diagrams depicting the reflection, refraction, polarization, or diffraction of waves. There is a strong misconception that the speed of EMR in a vacuum increases as the frequency of EMR increases. Many students are unable to correctly match diagrams of situations that produce spectra to the type of spectrum produced (e.g., absorption spectrum, emission spectrum, red- or blue-shifted spectra) but have greater success when asked to identify the components of a gas mixture from reference spectra.

### **General Outcome D1/D2: Energy and the Environment**

Most students are able to identify the main risks and benefits of particular energy-producing technologies and are able to interpret tables and graphs showing trends in energy production. They are also able to perform calculations related to efficiency. Students are generally able to distinguish among societal, legal, ethical, ecological, and economic issues and distinguish between renewable and non-renewable energy sources. They are less successful at balancing nuclear equations and calculating the energy produced during nuclear reactions. Students have difficulty identifying the relationship between nuclear decay and geothermal energy. There appears to be a misconception that radiant solar energy from the Sun is the source of geothermal energy. The greatest difficulty for students is with questions related to calculating molar heats of combustion or energy released in nuclear reactions.

---

## Clarifications and Depth of Coverage

The purpose of this section is to provide clarification and to describe the depth at which the [Science 30 Program of Studies](#) will be addressed on the *Science 30 Diploma Examination*.

The recommendations in this section were made by teacher committees working with Provincial Assessment staff at Alberta Education and Childcare. Added to these recommendations are examples of the types of questions that demonstrate the depth of coverage.

Regular-font items in the program of studies will be assessed on the diploma examination, and although items in italics will not be specifically tested, students should still be capable of addressing ideas and skills described in the italicized concepts on open-ended items used for classroom assessment. On the diploma examination, the italicized items could appear as distractors or the italicized items could appear in questions where more than one answer is possible.

## Unit A, General Outcome 1

Students will analyze how the human circulatory system facilitates interaction between blood cells and the external environment and investigate cardiovascular health.

Students are required to understand the structure and function of the circulatory system, including the four chambers of the heart, the septum, and the location and function of the four valves. Specific names of valves are not required. Identification of the blood vessels connected to each of the chambers of the mammalian heart and an ability to relate their differences in structure to their specific function is necessary, along with a general understanding of the structure and function of the various types of blood vessels. Students should be able to outline the pathway of the blood through the circulatory system.

A general description of systole and diastole is required. Calculation of stroke volume is not required.

A general understanding of the function of the main components of blood is required. It is reasonable to expect students to recognize the relationship between hemoglobin and oxygen transport. Students should be able to recognize the main components of blood from observations of prepared blood slides or electronic images of blood, and they should be able to compare the shape, relative size, and relative number of blood cells in blood. Students do not need to recognize the specific types of white blood cells observed in images of prepared blood slides (i.e., identifying neutrophils, lymphocytes, monocytes, eosinophils, or basophils is beyond the program of studies).

### Sample Questions

Students should be able to outline the pathway of blood through the circulatory system from any starting point in the circulatory system.

*Use the following information to answer numerical-response question 1.*

#### Some Blood Vessels in the Human Circulatory System

- 1 Vena cava
- 2 Vein in the arm
- 3 Pulmonary veins
- 4 Pulmonary artery

### Numerical Response

1. If a flu vaccination is administered into arm muscle and diffuses into blood capillaries, then the pathway of the vaccine once it enters a capillary is numbered \_\_\_\_\_ → \_\_\_\_\_ → \_\_\_\_\_ → \_\_\_\_\_ → Aorta

(Record all **four digits** of your answer in the numerical-response section on the answer sheet.)

The answer is 2143. Assessing A1.3k and A1.3s

Locating valves and understanding the function of valves is important; however, naming the valves is not necessary.

Use the following information to answer question 2.

A faulty heart valve allows blood to flow back into the previous heart chamber. In the past, this condition has been treated by replacing the faulty valve with a mechanical valve, like the one shown below.

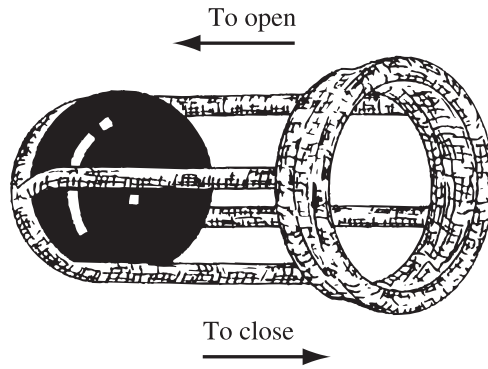

2. Which of the following diagrams shows a mechanical valve placed so that it would correct the backflow of blood through a faulty valve between the right atrium and right ventricle?

A.

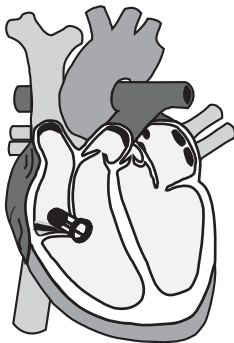

B.

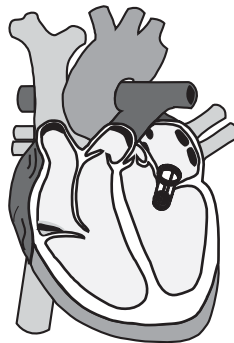

C.

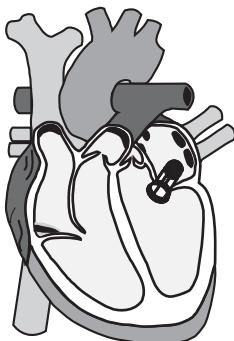

D.

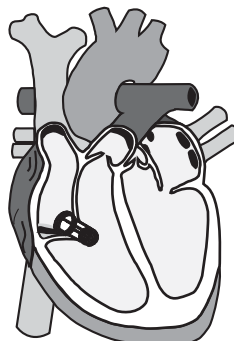

The answer is D. Assessing A1.1k, A1.3s, and A1.1sts

Identifying blood components from images or illustrations of blood and the effect of changes in relative numbers or functions of blood components is expected.

3. Which of the following diagrams shows a blood sample that was **most likely** taken from a person who was fighting an infection?

A.

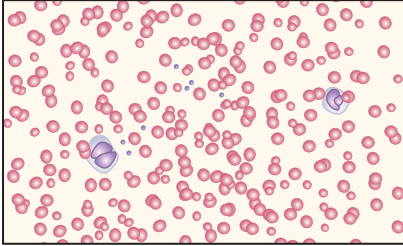

B.

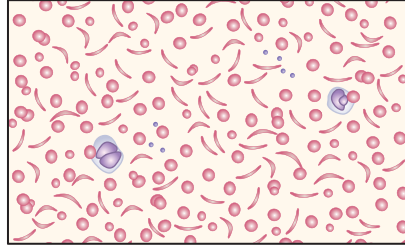

C.

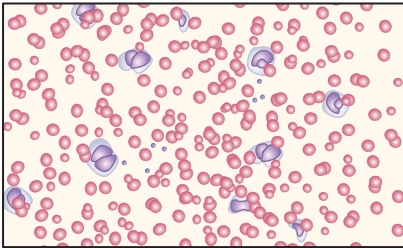

D.

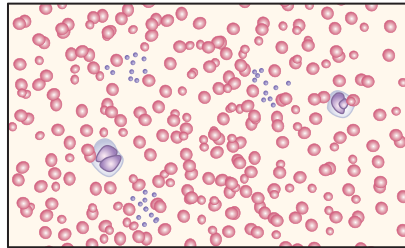

The answer is C. Assessing A1.4k and A1.2s

Students should be aware that both platelets and blood plasma are involved in blood clotting, but knowledge of the specific clotting-factor proteins is not required.

*Use the following information to answer question 4.*

Some pesticides that target rats and mice contain a chemical that disrupts an animal's ability to use vitamin K. Without vitamin K, an animal is unable to produce blood clots and may die from internal bleeding.

4. Which of the following pairs of blood components would have their functions **most directly** affected by the pesticide?
- A. Plasma and platelets
  - B. Plasma and red blood cells
  - C. White blood cells and platelets
  - D. White blood cells and red blood cells

The answer is A. Assessing A1.4k

Item contexts may focus on an understanding of scientific inquiry as described by skill outcomes in the program of studies.

*Use the following information to answer question 5.*

One hundred girls of the same age participated in a study to determine the effect of exercise on blood pressure. Fifty girls exercised for 60 min each day for one month. The other 50 girls did not participate in any exercise for one month. The blood pressure of each participant was taken at the beginning of each month.

5. Which of the following rows identifies the responding variable and the control group from the study above?

<b>Row</b>	<b>Responding Variable</b>	<b>Control Group</b>
<b>A.</b>	Exercise	Girls that exercised
<b>B.</b>	Exercise	Girls that did not exercise
<b>C.</b>	Blood pressure	Girls that exercised
<b>D.</b>	Blood pressure	Girls that did not exercise

The answer is D. Assessing A1.1s and A1.1sts

## Unit A, General Outcome 2

Students will analyze the defense mechanisms used by the human body to protect itself from pathogens found in the external environment.

Students are required to understand how the body protects itself against pathogens. Detailed knowledge of specific pathogens, such as their structures and mode of infection, is not required. Students should know about the development of immunity, failure to develop immunity, autoimmune disorders, and the role of vaccines and antibiotics. Knowledge of the specific types of antibiotics or the mechanisms by which they prevent bacteria from reproducing is not required; however, students should know that antibiotics can be used to treat bacterial infections. In General Outcome 3, students will extend this concept with the study of antibiotic resistance.

Suppressor T cells are now known as regulatory T cells; however, the term *suppressor T cells* will continue to be used on diploma examinations in order to be consistent with the program of studies and approved-resource terminology. Suppressor (regulatory) T cells suppress immune responses and play a critical role in preventing autoimmune diseases.

Students are required to have a general understanding of the roles of the white blood cells listed in the program of studies; describing the role of other white blood cells, such as neutrophils, eosinophils, or basophils, is not required.

### Sample Questions

Identifying the non-specific body mechanisms that form the first line of defence against pathogens is required.

6. An example of a non-specific body mechanism that prevents pathogens from entering tissues is
- A. tears
  - B. antigens
  - C. antibodies
  - D. killer T cells

The answer is A. Assessing A2.2k

7. Pathogens have unique substances on their surface called   *i*  .  
A type of white blood cell that uses these unique substances to recognize and then engulf pathogens is a   *ii*  .

The statements above are completed by the information in row

<b>Row</b>	<b><i>i</i></b>	<b><i>ii</i></b>
<b>A.</b>	antigens	killer T cell
<b>B.</b>	antigens	macrophage
<b>C.</b>	antibodies	killer T cell
<b>D.</b>	antibodies	macrophage

The answer is B. Assessing A2.3k

## Unit A, General Outcome 3

Students will apply the principles of heredity and molecular genetics to explain how human diseases can arise from inherited traits, the risks and benefits of genetic technology, and the need for ethical considerations in the application of scientific knowledge.

The principles of heredity should be explained using simple Mendelian genetics. Students are required to predict genotypic and phenotypic ratios and percentages that result from monohybrid crosses and to be able to analyze a pedigree chart. Students are not required to have knowledge of incomplete dominance, codominance, or dihybrid crosses.

Memorization of the names of the stages of mitosis and meiosis is not required, but a general description and ordering of the sequence of events in these processes is required. Students should also be able to identify and sequence a series of microscope images showing the stages of mitosis. For example, students should know that chromosomes double, line up at the equator, separate, and migrate to opposite poles. The same depth should apply to meiosis and fertilization. Students are expected to use the terms *haploid* ( $1n$ ) and *diploid* ( $2n$ ) and *homozygous* and *heterozygous* (carrier) in their descriptions. Students should be able to relate meiosis and fertilization to Mendelian crosses as represented by Punnett squares.

Students should be able to interpret autosomal dominant, autosomal recessive, sex-linked dominant, and sex-linked recessive patterns of inheritance. Sex-linked genetic traits include both X-linked and Y-linked genetic disorders, and students should understand the terms *X-linked* and *Y-linked*.

The general characteristics of the structure and function of DNA should be understood. Students are expected to identify complementary nitrogen base pairs. A general description of the main events of DNA replication (such as the molecule unzipping and new specific bases linking) and protein synthesis is required, but a detailed understanding of transcription and translation, including the roles of tRNA, ribosomes, mRNA, and DNA enzymes, is not required.

**Students should be able to use the table on page 13 of the data booklet. This table is different from the one used in Biology 30 for coding from a DNA sequence to an amino acid sequence.** The table uses the complementary ( $5' \rightarrow 3'$ ) strand of DNA as the code for determining the amino acid sequence. The scientific community often uses this strand to report on DNA sequences and mutations. This may cause some problems with students who take Science 30 along with Biology 30. Biology 30 resources have historically used the template ( $3' \rightarrow 5'$ ) strand in order to show how that strand is transcribed into mRNA. The table that Biology 30 students use to determine the amino acid sequence is usually an mRNA table. The table for mRNA is the same as for the complementary strand of DNA that is used in the data booklet, except that in the data booklet, uracil (U) is replaced by thymine (T).

Students should understand that DNA has two functions: 1) to pass on information to offspring; and 2) to code for the production of proteins.

Science 30 students should have a general understanding of various types of proteins and their roles, such as those described in the table below.

---

<b>Type of Protein</b>	<b>Role of Protein</b>
Enzymes	Speed up chemical reactions in the body
Hormones	Act as signals to coordinate and regulate activities in the body
Structural	Support cells and provide frameworks for other proteins to attach to
Transport	Allow the movement of materials within cells or the body (e.g., hemoglobin)
Defensive	Protect the body from pathogens (e.g., antibodies)
Energy	Decomposition of protein can serve as a source of energy

---

### Sample Questions

Students are required to describe the chromosomal content of cells undergoing mitosis or meiosis.

Use the following information to answer question 8.

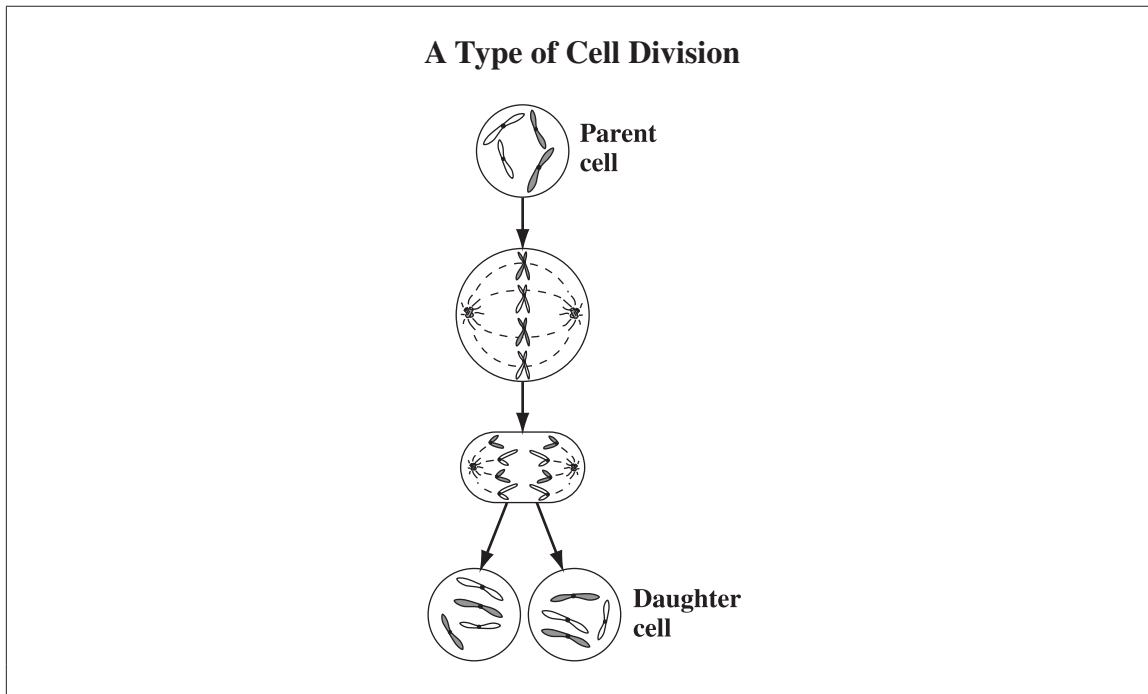

8. The change in chromosomal content from the parent cell to a daughter cell, as illustrated above, can be described as
- A.  $4n \rightarrow 1n$
  - B.  $4n \rightarrow 2n$
  - C.  $2n \rightarrow 2n$
  - D.  $2n \rightarrow 1n$

The answer is C. Assessing A3.1k

Identifying the general functions of proteins is required of students; however, only the proteins listed in the program of studies will be directly assessed (i.e., antibodies, hemoglobin, and antigens).

*Use the following information to answer numerical-response question 9.*

<b>Protein</b>	<b>Function</b>	<b>Classification</b>
<b>1</b> Antibody	<b>3</b> Delivers oxygen	<b>6</b> Defensive
<b>2</b> Hemoglobin	<b>4</b> Speeds up reactions	<b>7</b> Enzyme
	<b>5</b> Attaches to pathogens	<b>8</b> Transport

### **Numerical Response**

- 9.** Using the numbers above, choose **one protein** and match it with its function and with its classification. (There is more than one correct answer.)

**Number:**                                               
                  **Protein**        **Function**        **Classification**

(Record all **three digits** of your answer in the numerical-response section on the answer sheet.)

The answers are 156 or 238. Assessing A1.4k, A2.3k, and A3.7k

Use the following information to answer numerical-response question 10.

### Descriptions of Some Biological Molecules

- 1 Code for hereditary traits
- 2 Composed of nucleotides
- 3 Composed of amino acids
- 4 Structural components in cells
- 5 Can be a source of energy for body cells
- 6 Can act as enzymes that speed up chemical reactions

### Numerical Response

- 10.** The descriptions above that apply to proteins are numbered \_\_\_\_\_, \_\_\_\_\_, \_\_\_\_\_, and \_\_\_\_\_.

(Record all **four digits** of your answer **in any order** in the numerical-response section on the answer sheet.)

The answer is 3456. Assessing A3.7k



Students are required to assess the risks and benefits of genetic technologies.

*Use the following information to answer question 12.*

One type of food plant was genetically modified (GM) by inserting the gene from a bacterium into the genetic material of the plant. These GM plants produce a substance that is poisonous only to certain insects.

- 12.** An environmental benefit of growing the GM plant is that
- A.** genes that code for the poisonous substance may be transferred from the GM plants to other organisms
  - B.** the use of harmful pesticides may be avoided for crops of the GM plants
  - C.** non-target insects who feed on the GM plants may be affected
  - D.** the yield of food from crops of the GM plants may increase

The answer is B. Assessing A3.9k and A3.2sts

The ability to interpret pedigree charts and use appropriate symbols to describe specific genotypes is a requirement of the course.

Use the following information to answer questions 13 and 14.

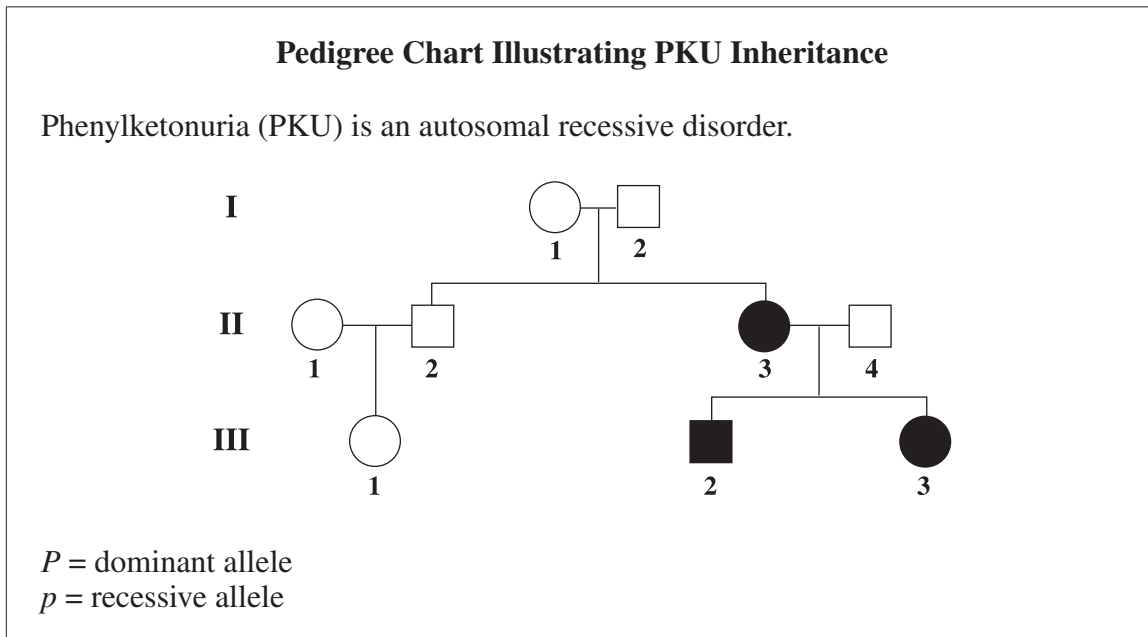

13. The genotype of individual **II-4** is

- A.  $PP$
- B.  $Pp$
- C.  $Pp$  or  $PP$
- D.  $PP$  or  $pp$

The answer is B. Assessing A3.2k and A3.2s

14. Which of the following people represented on the pedigree chart has a homozygous genotype?

- A. I-1
- B. I-2
- C. II-3
- D. II-4

The answer is C. Assessing A3.2k, A3.2s, and A3.3.s

Given a pedigree chart, students should be able to determine the mode of inheritance of autosomal dominant, autosomal recessive, X-linked dominant, X-linked recessive, or Y-linked traits or disorders.

Use the following information to answer question 15.

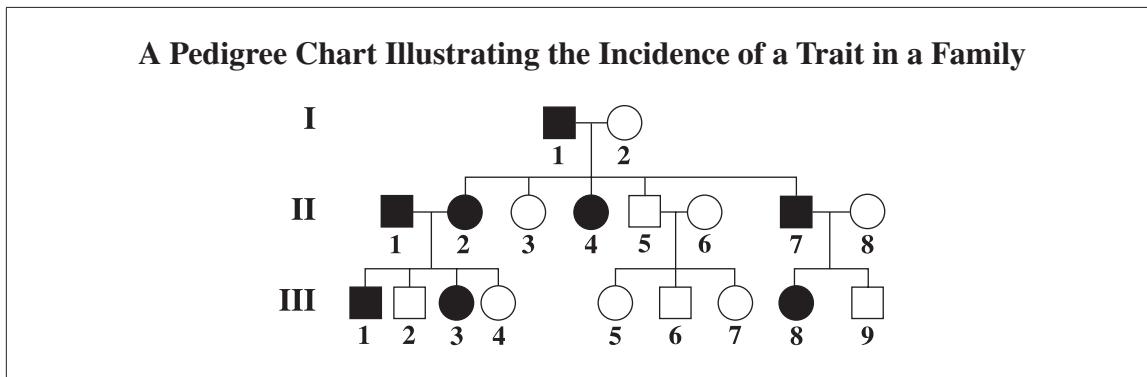

15. Based on the pedigree chart above, the mode of inheritance for the trait is **most likely**
- A. autosomal recessive
  - B. autosomal dominant
  - C. X-linked recessive
  - D. X-linked dominant

The answer is B. Assessing A3.3k, A3.2s, and A3.3s

Students are required to describe the development of antibiotic resistance in bacteria using the concepts of mutation, plasmid transfer, transformation, and natural selection.

*Use the following information to answer question 16.*

Resistance to antibiotic drugs in bacterial populations has been observed over time.

- 16.** One of the reasons that bacterial populations have developed resistance to antibiotics is because
- A.** antibiotics biomagnify in the bacterial population
  - B.** some bacteria develop tolerance to large amounts of antibiotics
  - C.** plasmids with antibiotic-resistant genes are transferred between individual bacteria
  - D.** the more bacteria are exposed to antibiotics, the less resistant the population becomes

The answer is C. Assessing A3.10k

Genetic engineering and gene therapy are the two main genetic processes that students should be familiar with.

*Use the following information to answer question 17.*

Type 1 diabetes is an autoimmune disease that stops the pancreas from producing the hormone insulin. A lack of insulin decreases a person's ability to regulate blood-glucose levels.

Researchers are investigating the possibility of inserting the section of DNA that codes for insulin production into a virus as part of a possible cure for type 1 diabetes. In this method, patients swallow the virus containing the DNA fragment; the virus inserts the DNA fragment into the cells of the patient's intestine, and then the patient's intestinal cells begin to produce insulin.

- 17.** The method described above is an example of
- A.** gene therapy
  - B.** plasmid transfer
  - C.** natural selection
  - D.** genetic screening

The answer is A. Assessing A3.9k and A3.1sts

## Unit B, General Outcome 1

Students will analyze the sources of acids and bases and their effects on the environment.

Students are required to describe acid–base interactions in terms of proton donors and proton acceptors. The term *Brønsted–Lowry* is not required. Assessment of acid–base reactions will be limited to single proton transfers on the *Science 30 Diploma Examination*. Students should be familiar with the terms *conjugate acid* and *conjugate base*. Titration calculations are limited to monoprotic acids and monoprotic bases. Students are expected to analyze titrations involving combinations of a strong acid and strong base, a strong acid and weak base, or a weak acid and strong base. Students do not need to calculate the hydronium ion concentration of a weak acid using  $K_a$  values. Students should be able to rank acids using the table of relative acid strengths in the data booklet. Students should be able to identify that strong acids, such as  $\text{HCl}(\text{aq})$ ,  $\text{H}_2\text{SO}_4(\text{aq})$ , and  $\text{HNO}_3(\text{aq})$ , ionize completely, whereas weak acids only partially ionize. Students are expected to interpret but not to generate titration curves. Students should be able to determine the pH range from the colour of an indicator added to a solution. Students should be aware of the logarithmic nature of the pH scale.

Students are expected to test for acidic, basic, neutral ionic, and neutral molecular solutions using a variety of diagnostic tests. Diagnostic tests could include conductivity meters, pH meters, indicators, and reactions with active metals like magnesium or zinc. Naming of ionic and molecular compounds or acids and bases is not a focus in this general outcome; instead, the focus is on students classifying a solution using its chemical formula. For example, it is more important for students to recognize that  $\text{HNO}_3(\text{aq})$  is a strong acid and that  $\text{NaCl}(\text{aq})$  is a neutral ionic solution than it is for students to provide the IUPAC names of these compounds.

Outcome B1.3s states that students are expected to “research and plot on a map the distribution of acid deposition as influenced by prevailing winds.” Therefore, students should be familiar with the fact that the prevailing wind direction across Alberta, and all of North America, is from west to east. Given cardinal directions, students should be able to apply their knowledge of prevailing winds to identify the location on a map that would be most affected by acid-forming emissions.

Although B1.8k states that nitrous oxides produce acid deposition, dinitrogen oxide (nitrous oxide),  $\text{N}_2\text{O}(\text{g})$ , does not contribute to acid deposition. This outcome refers to the oxides of nitrogen (i.e.,  $\text{NO}(\text{g})$  and  $\text{NO}_2(\text{g})$ ).

Students are expected to understand that metal leaching is a possible result of acid deposition as an extension of B1.9k and B2.1sts.

### Sample Questions

In order to accurately represent what happens in a buffer system, equilibrium arrows will be used in reaction equations. The concept of equilibrium will not be tested, but students should be aware that protons can be donated and accepted in both the forward and the reverse reactions. The term *Brønsted–Lowry* is not used for assessment.

*Use the following information to answer question 18.*

#### Chemical Equation Representing Buffering Action

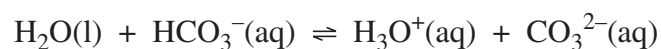

18. Which two substances represented in the equation above donate a proton?
- A.  $\text{H}_2\text{O}(\text{l})$  and  $\text{H}_3\text{O}^+(\text{aq})$
  - B.  $\text{H}_2\text{O}(\text{l})$  and  $\text{CO}_3^{2-}(\text{aq})$
  - C.  $\text{HCO}_3^-(\text{aq})$  and  $\text{H}_3\text{O}^+(\text{aq})$
  - D.  $\text{HCO}_3^-(\text{aq})$  and  $\text{CO}_3^{2-}(\text{aq})$

The answer is C. Assessing B1.1k

Students should be aware of the logarithmic nature of the pH scale.

*Use the following information to answer question 19.*

The pH of a sample of melted snow is 5.5 and changes to a pH of 7.5 when it enters a pond.

19. Which of the following statements describes the change in hydronium ion concentration,  $[\text{H}_3\text{O}^+(\text{aq})]$ , as the melted snow enters the pond?
- A. The  $[\text{H}_3\text{O}^+(\text{aq})]$  increased by a factor of 2.
  - B. The  $[\text{H}_3\text{O}^+(\text{aq})]$  decreased by a factor of 2.
  - C. The  $[\text{H}_3\text{O}^+(\text{aq})]$  increased by a factor of 100.
  - D. The  $[\text{H}_3\text{O}^+(\text{aq})]$  decreased by a factor of 100.

The answer is D. Assessing B1.3k and B1.3s

Students should be able to interpret the results of simple diagnostic tests such as conductivity and indicator colour, including intermediate indicator colours. Students should be able to classify compounds from chemical formulas.

*Use the following information to answer question 20.*

A sample solution is tested for conductivity and pH. The results of these tests compared with the results of the same tests using distilled water are shown in the table below.

Sample	Conductivity	Colour After Addition of Indicator		
		Bromothymol Blue	Phenolphthalein	Bromocresol Green
Distilled water	None	Green	Colourless	Blue
Sample solution	High	Yellow	Colourless	Green

**20.** Based on the test data shown above, the sample solution above could be

- A.  $\text{NaCl(aq)}$
- B.  $\text{NaOH(aq)}$
- C.  $\text{H}_2\text{SO}_3\text{(aq)}$
- D.  $\text{CH}_3\text{OH(aq)}$

The answer is C. Assessing B1.2k and B1.2s

Students should be able to make general interpretations of titration curves involving monoprotic acids.

Use the following information to answer question 21.

A 10.0 mL sample of well water was titrated with a 0.100 mol/L solution of HCl(aq). As the titration progressed, the pH of the well water was measured and recorded on the following graph.

**Change in pH of Well-water Sample Titrated with HCl(aq)**

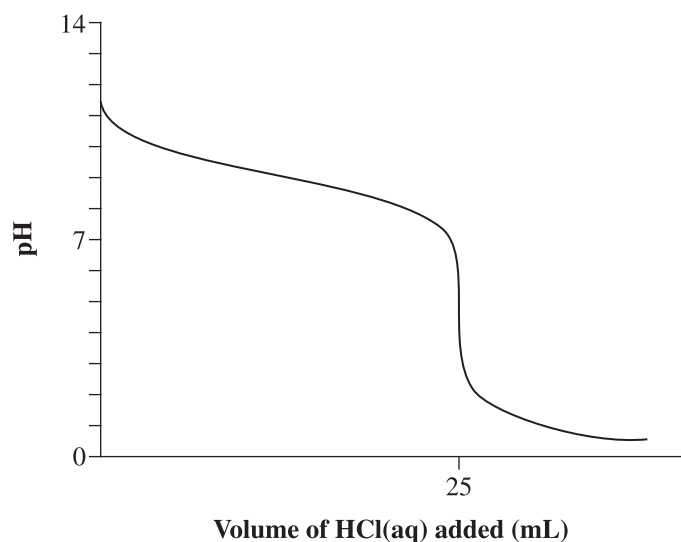

21. According to the graph above, the water sample initially had a pH that was   *i*  . As HCl(aq) was added, the hydronium ion concentration,  $[H_3O^+(aq)]$ , of the water sample   *ii*  .

The statements above are completed by the information in row

Row	<i>i</i>	<i>ii</i>
A.	greater than 7	increased
B.	greater than 7	decreased
C.	less than 7	increased
D.	less than 7	decreased

The answer is A. Assessing B1.4k and B1.3s

The ability to write chemical equations for and to predict the products of combustion reactions resulting in acid deposition is required.

*Use the following information to answer question 22.*

Low-grade coal has a high sulfur content. The burning of low-grade coal contributes to harmful emissions that can undergo chemical reactions in the atmosphere.

22. *When the sulfur present in low-grade coal is burned, it forms   i  , which can react with water in the atmosphere to form   ii  .*

The statement above is completed by the information in row

<b>Row</b>	<b><i>i</i></b>	<b><i>ii</i></b>
<b>A.</b>	SO <sub>2</sub> (g)	H <sub>2</sub> SO <sub>4</sub> (aq)
<b>B.</b>	SO <sub>2</sub> (g)	S <sub>8</sub> (s)
<b>C.</b>	H <sub>2</sub> S(g)	H <sub>2</sub> SO <sub>4</sub> (aq)
<b>D.</b>	H <sub>2</sub> S(g)	S <sub>8</sub> (s)

The answer is A. Assessing B1.8k and B1.2sts

## Unit B, General Outcome 2

Students will analyze the sources of organic compounds and their effects on the environment.

Students should focus on naming and identifying a compound based on functional groups (see [Science Data Booklet](#), page 9). Students are not required to name complex compounds. Naming organic compounds is limited to a three-carbon parent chain. Students are expected to recognize expanded, condensed, line structural diagrams, and molecular models that represent organic compounds. Aldehydes, ketones, and polymers are not part of the Science 30 Program of Studies.

The term *hydrocarbon* should be strictly limited to describing molecules composed of only carbon and hydrogen atoms. For organic molecules composed of other atoms, including oxygen and halogens, the term *hydrocarbon derivative* is appropriate.

The benzene ring may be represented as shown in diagrams 1 and 2 below.



Diagram 1



Diagram 2

---

Students should recognize that carbon dioxide, methane, and CFCs are greenhouse gases and that increased emission of these gases contributes to climate change.

Students should be aware that photochemical smog is one type of smog produced by reactions involving sunlight,  $\text{NO}_x$ , and ground-level ozone.  $\text{NO}_x$  includes nitrogen monoxide,  $\text{NO}(\text{g})$ , and nitrogen dioxide,  $\text{NO}_2(\text{g})$ , but does not include dinitrogen monoxide (nitrous oxide),  $\text{N}_2\text{O}(\text{g})$ . A major source of photochemical smog is emissions from internal combustion engines. Other types of air pollution, such as  $\text{SO}_x$  emissions and particulates from coal combustion, contribute to industrial smog, but these pollutants do not contribute to photochemical smog.

### Sample Questions

Naming complex benzene derivatives is not required; however, identifying functional groups attached to complicated structures is expected. Students do not need to know the order of precedence for functional groups.

*Use the following information to answer question 23.*

#### Structural Formula of a Component of a Medication

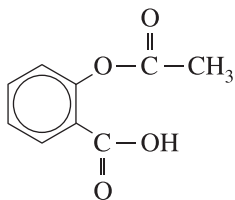

23. Two functional groups represented in the diagram above are the same as those found in
- A. esters and alcohols
  - B. esters and carboxylic acids
  - C. halogenated hydrocarbons and alcohols
  - D. halogenated hydrocarbons and carboxylic acids

The answer is B. Assessing B2.1k

Students should be able to recognize a variety of organic compound representations.

*Use the following information to answer question 24.*

A student uses a molecular model kit to build a model of an organic compound.

**Model of an Organic Compound**

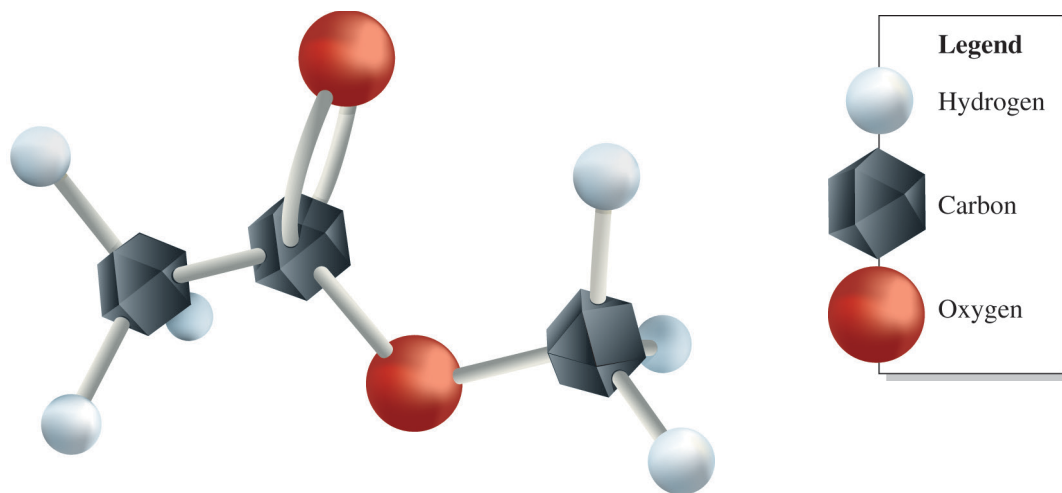

24. The model is a representation of
- A. an ester
  - B. an alcohol
  - C. a carboxylic acid
  - D. a halogenated hydrocarbon

The answer is A. Assessing B2.1k

Students should be able to identify sources and hazards of benzene derivatives and identify benzene derivatives based on the presence of one or more benzene rings.

*Use the following information to answer question 25.*

When some aquatic micro-organisms are exposed to benzene derivatives, they produce a particular type of protein, called a stress protein. The presence of the stress protein can be an indication of poor water quality.

**25.** Which of the molecules shown below would result in the production of the stress protein in some aquatic micro-organisms?

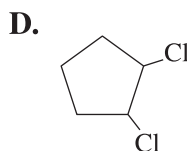
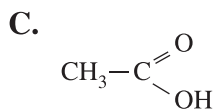
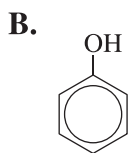
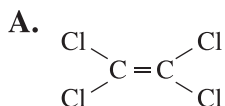

The answer is B. Assessing B2.4k

Students should be able to classify organic compounds as halogenated hydrocarbons, CFCs, dioxins, furans, or polychlorinated bipheyls (PCBs) based on their chemical structure.

Students should recognize that a dioxin is an organic compound with a hexagonal ring structure containing four carbon atoms and two oxygen atoms. Students should be aware that polychlorinated dibenzodioxins are a type of toxic and persistent dioxin derivative that bioaccumulate in food chains and exposure to polychlorinated dibenzodioxins can lead to cancer and other long-lasting health issues. Polychlorinated dibenzodioxins can be produced from natural sources, such as forest fires or volcanic eruptions, but mainly they are the by-product of industrial processes. The largest source of dioxins in Canada is the large-scale burning of municipal and medical waste. The chemical structure of dioxin and the chemical structure of a polychlorinated dibenzodioxin with the distinctive dioxin ring structure are shown below.

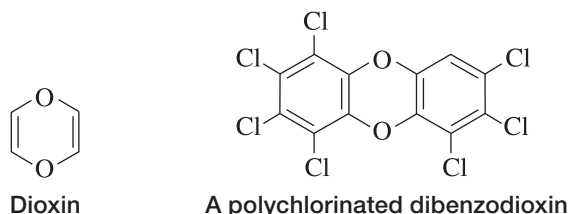

Students should recognize that furan is an organic compound with a pentagonal ring structure containing four carbon atoms and one oxygen. Chemical compounds that have this pentagonal ring structure are also commonly referred to as furans. Polychlorinated dibenzofurans are furan derivatives that have similar properties to polychlorinated dibenzodioxins and come from the same sources. The chemical structure of furan and the chemical structure of a polychlorinated dibenzofuran with the distinctive furan ring structure are shown below.

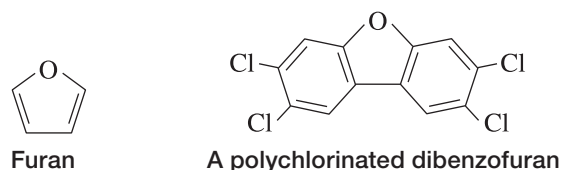

PCBs are organic compounds that can be recognized by looking for two linked benzene rings in which some or all of the hydrogen atoms have been substituted by chlorine atoms. The  $x$  and  $y$  in the generalized structure below represent between 1 and 5 chlorine atoms.

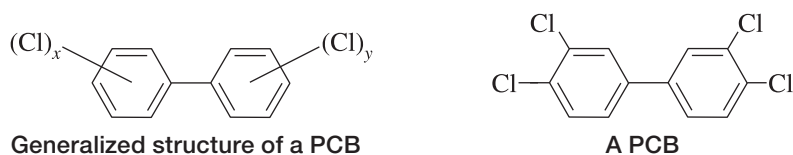

Use the following information to answer numerical-response question 26.

### Structural Diagrams of Some Halogenated Organic Compounds

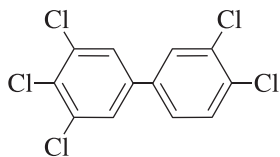

1

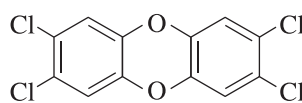

2

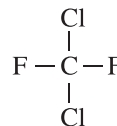

3

### Numerical Response

26. Match each of the organic compounds numbered above with its classification given below. (Use each number only once.)

Compound: \_\_\_\_\_  
Classification: **Dioxin**      **PCB**      **CFC**

(Record all **three digits** of your answer in the response boxes at the bottom of the screen.)

The answer is 213. Assessing B2.3k

Students should be able to identify the main sources of, effects of, and alternatives to the harmful halogenated hydrocarbons described in B2.3k and B2.4k.

Use the following information to answer question 27.

**A Persistent Organic Pollutant**

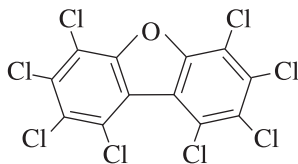

27. Which of the following rows identifies a major source of pollutants like the one shown above and some health hazards caused by exposure to these type of pollutants?

Row	Major Source of Pollutant	Health Hazards
A.	Burning municipal and medical waste	Difficulty breathing and development of asthma
B.	Burning municipal and medical waste	Impairment of the immune system and development of certain types of cancer
C.	Producing refrigerants for air conditioners	Difficulty breathing and development of asthma
D.	Producing refrigerants for air conditioners	Impairment of the immune system and development of certain types of cancer

The answer is B. Assessing B2.3k, B2.4k, and B2.1sts

Use the following information to answer numerical-response question 28.

**Some Pollutants**

- 1 PCBs
- 2 CFCs
- 3 Dioxins
- 4 Pesticides

**Numerical Response**

**28.** Match each pollutant numbered above with a source of that pollutant given below.

Old refrigerators \_\_\_\_\_ (Record in the **first** column)

Old transformers \_\_\_\_\_ (Record in the **second** column)

Waste incineration \_\_\_\_\_ (Record in the **third** column)

Agricultural runoff \_\_\_\_\_ (Record in the **fourth** column)

(Record your answer in the numerical-response section on the answer sheet.)

The answer is 2134. Assessing B2.3k

## Unit B, General Outcome 3

Students will analyze, from a variety of perspectives, the risks and benefits of using chemical processes in meeting human needs and assess technologies for reducing the impact of chemical compounds on the environment.

The concepts in General Outcome B3 will most often be assessed within the context of the substances and processes studied in General Outcomes B1 and B2. The main sources of, effects of, and potential solutions to listed pollutants should be understood. For example, overuse of some pesticides leads to biomagnification and the death of species at the top of the food chain. Students are not required to memorize a detailed series of chemical reactions to explain the cause and effect of certain air pollutants on our environment; simplified single-step chemical reaction equations are adequate. Students are expected to understand the basic water-quality tests as listed in B3.3s. Students are expected to identify the WHMIS 2015 pictograms.

An understanding of pesticide resistance is required.

Students are expected to evaluate environmental issues from multiple perspectives. These perspectives, or viewpoints, include environmental, economic, ethical, political, scientific, technological, legal, or societal considerations.

### Sample Questions

Students are expected to interpret data from water-quality tests.

29. *If the water from a particular location in a river has a high organic content, then the BOD of the water would be expected to be   i  . Downstream from this location the dissolved oxygen content of the water would be expected to be   ii  .*

The statements above are completed by the information in row

Row	<i>i</i>	<i>ii</i>
A.	low	low
B.	low	high
C.	high	low
D.	high	high

The answer is C. Assessing B3.3s

Students are expected to evaluate environmental issues from more than one perspective.

30. From an environmental perspective, the **main** reason that sulfur should be removed from coal is to
- A. reduce the  $\text{SO}_2(\text{g})$  emissions that occur when coal is burned
  - B. make the coal burn hotter, which makes it more efficient
  - C. purify the water released by coal-mining operations
  - D. recover the sulfur for industrial purposes

The answer is A. Assessing B1.8k, B3.2k, and B2.1sts

Students should be able to match each WHMIS 2015 pictogram to the appropriate hazard. See page 88 for more information on WHMIS 2015.

*Use the following information to answer question 31.*

Painters should wear a mask to prevent them from breathing in chemicals present in paint fumes that could cause long-term breathing problems.

31. Which of the following WHMIS pictograms should be used to warn people of the danger of breathing in paint fumes?

A.



B.



C.



D.



The answer is A. Assessing B3.1s

## Unit C, General Outcome 1

Students will explain field theory and analyze its applications in technologies used to produce, transmit, and transform electrical energy.

The emphasis of this general outcome is on the basic principles of field theory. Some problems may involve solutions that require more than one step. Students should understand that the strength of an electric field or a gravitational field is inversely proportional to the square of the distance from the point source of the field. One way for students to visualize this concept is graphically, as shown below.

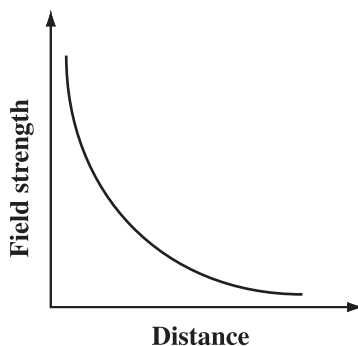

Students should be able to identify, compare, draw, and build series circuits and parallel circuits. However, calculations involving circuits with complicated combinations of series and parallel configurations are not required. Students are expected to evaluate energy production and technological devices from an economic perspective; this may include determining the cost of electricity after calculating the energy consumed, comparing energy data from devices to identify the most cost-effective device, or analyzing the cost savings of increasing the efficiency of a device.

Students should be able to relate the concept of induction to generators and transformers. Students should be able to analyze descriptions or diagrams of transformers to calculate current, voltage, or number of turns in the primary or secondary coils. Unless otherwise specified, it should be assumed that the transformer is ideal (i.e., energy is not lost in transformation).

Program of studies outcome C1.10k requires students to describe the advantage of using AC over DC for electrical energy transmission; however, with advances in ultra-high voltage (>500 V) electrical energy transmission using direct current (HVDC), there are now fewer advantages of using AC over ultra-high voltage DC for transmission. This distinction will be reflected in diploma examination questions.

Students are not required to solve for radius or mass using the gravitational field strength formula, and they are not required to solve for radius or charge using the electric field strength formula.

### Sample Questions

Students are expected to analyze situations involving gravitational and electric fields mathematically and conceptually.

*Use the following information to answer question 32.*

A metal sphere has a charge of  $3.90 \times 10^{-11}$  C and an electric field strength of 22.4 N/C at a distance of 0.125 m from the sphere.

**32.** The electric field strength of the sphere at a distance of  $3r$  would be

- A. 2.49 N/C
- B. 3.73 N/C
- C. 7.48 N/C
- D. 67.3 N/C

The answer is A. Assessing C1.4k and C1.3s

Students may need to use values provided in the data booklet, such as Earth's mass, to solve problems.

**33.** Earth's gravitational field strength  $4.2 \times 10^7$  m from the centre of Earth is

- A.  $2.3 \times 10^{-1}$  N/kg
- B.  $9.5 \times 10^{-1}$  N/kg
- C.  $2.3 \times 10^5$  N/kg
- D.  $9.5 \times 10^5$  N/kg

The answer is A. Assessing C1.3k and C1.3s

Students should understand that vector fields include direction.

34. Which of the following diagrams illustrates the direction of a magnetic field near the opposite poles of two magnets?

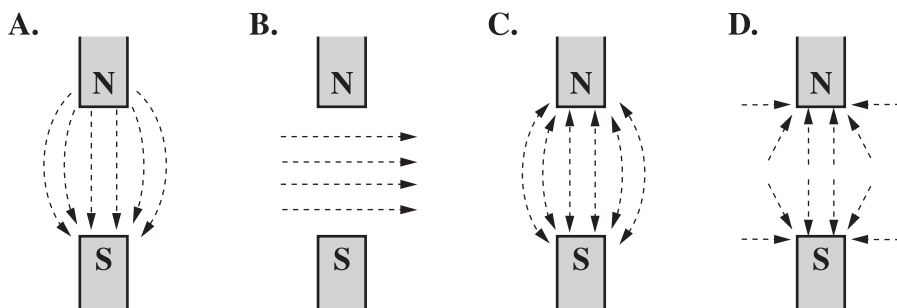

The answer is A. Assessing C1.3k and C1.2s

Students are expected to describe the effect of a conductor moving through a magnetic field.

*Use the following information to answer question 35.*

A coil of wire is rotated in the magnetic field of a U-shaped magnet. A current is generated in the coil of wire and measured by an ammeter.

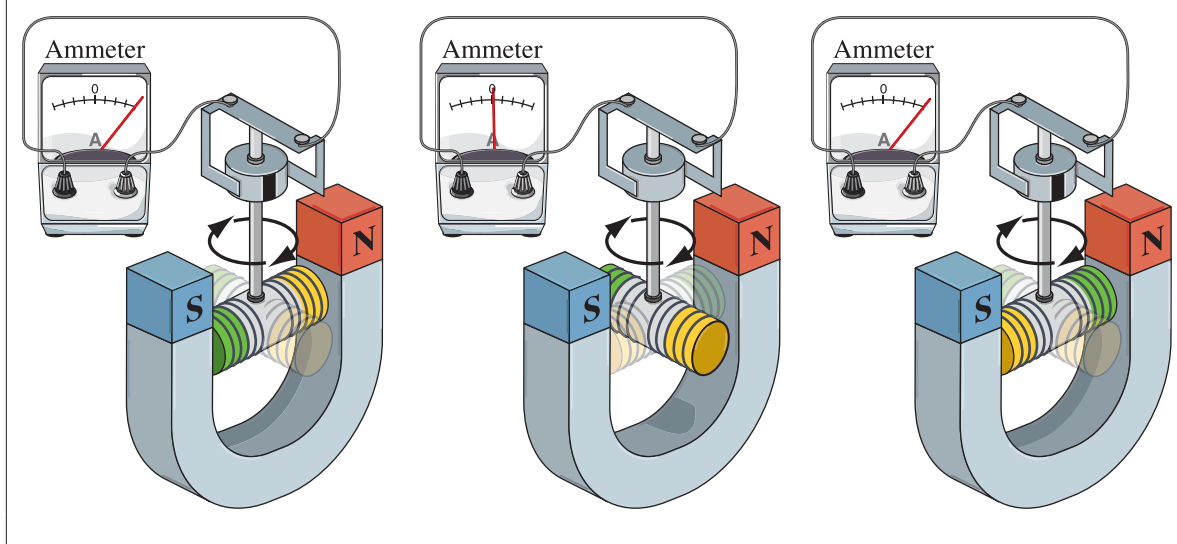

35. The diagram above illustrates the process of

- A. induction
- B. resistance
- C. stepping up voltage
- D. stepping down voltage

The answer is A. Assessing C1.5k and C1.11k

Students are required to compare the design and function of DC motors and generators.



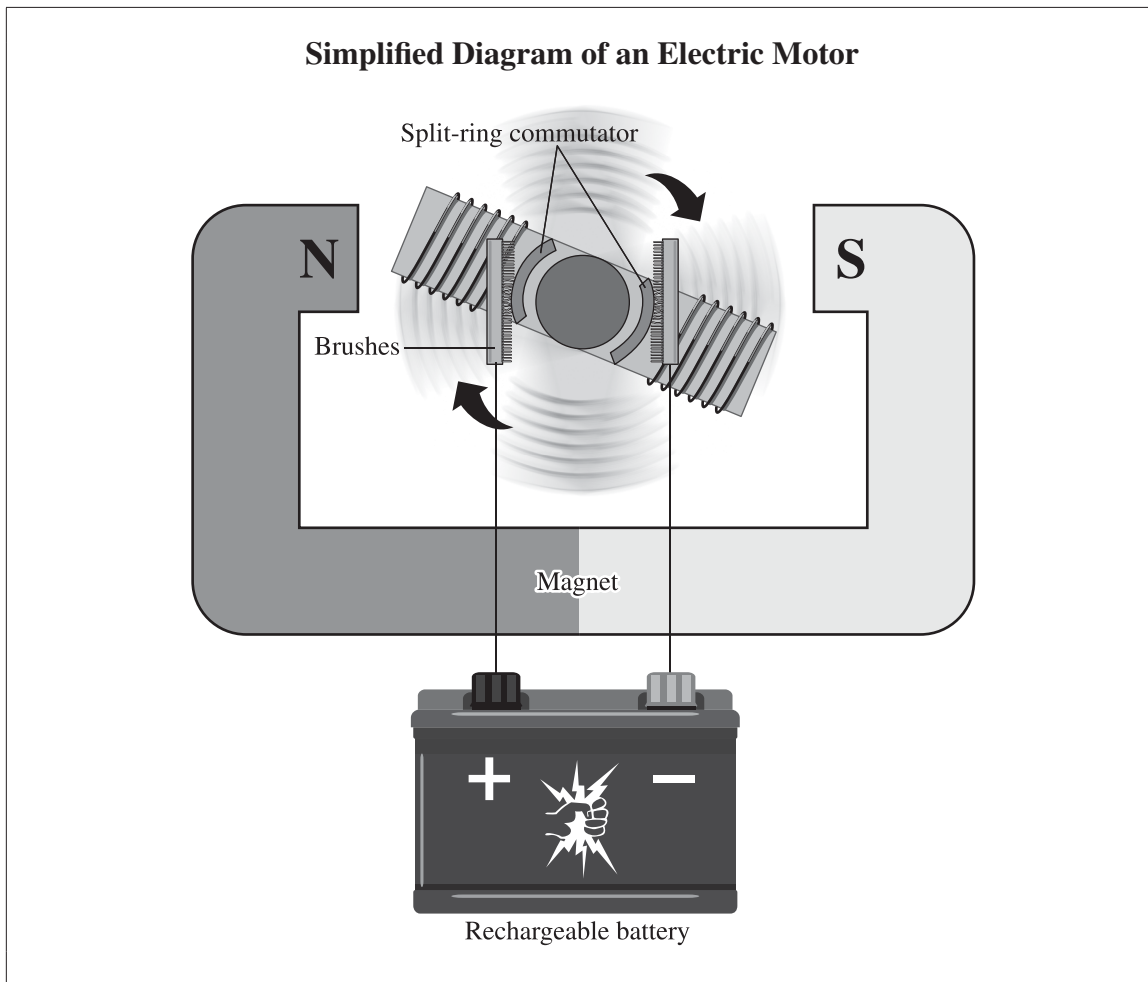





Use the following information to answer question 36.



36. Which of the following sequences identifies the energy changes that occur during the operation of the electric motor?
- A. chemical potential energy → kinetic energy of the spinning armature → electrical energy
  - B. chemical potential energy → electrical energy → kinetic energy of the spinning armature
  - C. kinetic energy of the spinning armature → electrical energy → chemical potential energy
  - D. kinetic energy of the spinning armature → chemical potential energy → electrical energy

The answer is B. Assessing C1.11k

Students should be familiar with the commonly used circuit symbols shown in the table below.

<b>Circuit Component</b>	<b>Symbol</b>	<b>Circuit Component</b>	<b>Symbol</b>
Battery		Switch	
Power source		Ammeter	
Bulb		Voltmeter	
Resistor		Ohmmeter	

Students are required to construct and analyze electric circuits, which can be accomplished using lab equipment or using computer simulations.

Use the following information to answer numerical-response question 37.

**Four Electric Circuits**

**1**

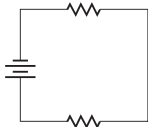

**2**

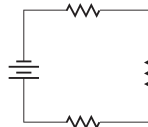

**3**

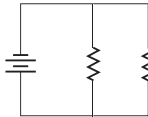

**4**

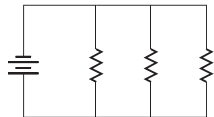

The resistors and batteries in each of the circuits above are identical.

**Numerical Response**

**37.** Listed in order from the circuit with **least** resistance to the circuit with **greatest** resistance, the four circuits above are

\_\_\_\_\_ , \_\_\_\_\_ , \_\_\_\_\_ , and \_\_\_\_\_ .  
**Least** resistance **Greatest** resistance

(Record all **four digits** of your answer in the numerical-response section on the answer sheet.)

The answer is 4312. Assessing C1.6k and C1.3s

## Unit C, General Outcome 2

Students will describe the properties of the electromagnetic spectrum and their applications in medical technologies, communication systems, and remote-sensing technologies used to study the universe.

Memorization of the various types of EMR is not necessary; this information is in the data booklet. The term *photon* may be used in comparisons of the various constituents of the electromagnetic spectrum on the basis of energy and their effect on living tissue. For refraction and reflection, the direction of EMR travel may be described relative to a normal line (i.e., a line perpendicular to the surface). Students should also be aware that the angle of incidence is equal to the angle of reflection. Calculations using Snell's law are not required.

EMR can be compared in terms of penetrability of Earth's atmosphere and its effect on living tissue. In the chart on page 3 of the data booklet, any EMR found to the right of visible light is a form of ionizing radiation, which links C2.2k with D2.6k and A3.8k. Students should be able to identify types of EMR that are blocked by Earth's atmosphere and types of EMR that can penetrate the atmosphere.

Note that in the data booklet diagram of the electromagnetic spectrum, the scale for the wavelengths of EMR types is independent of the scale for the frequencies of EMR types, and both scales are expressed in orders of magnitude. Students should use the universal wave equation to calculate frequency from a given wavelength, rather than reading across scales on the diagram. Students should be able to calculate speed of EMR in media other than air or in a vacuum.

Students should be able to identify different types of spectra and their sources. Students should be aware that Doppler-shift technology can be used to determine both the speed of a distant star and whether the star is moving toward or away from the observer. A general knowledge of the life cycle of stars is important, but using the Hertzsprung–Russell diagram is not required. Students should be aware that low-mass, intermediate-mass, and high-mass stars evolve to form white dwarfs, neutron stars, and black holes, respectively.

### Sample Questions

When comparing EMR in terms of energy, the term *photon* may be used.

38. Which of the following types of EMR has photons with **higher** energy than photons of ultraviolet EMR?
- A. X-ray
  - B. Radio
  - C. Infrared
  - D. Microwave

The answer is A. Assessing C2.2k

The term *normal* may be used to describe the direction in which the light is refracted or reflected.

39. Which of the following diagrams illustrates the expected pathway of a reflected light ray?

A.

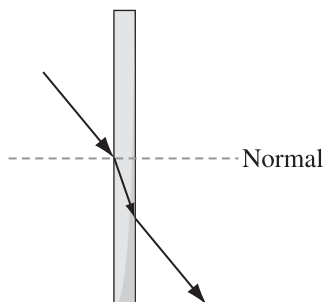

B.

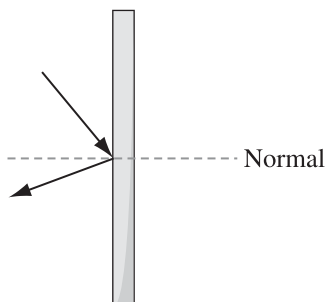

C.

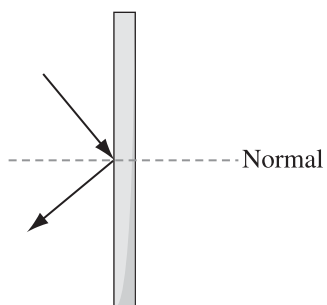

D.



The answer is C. Assessing C2.4k and C2.2s

Students should be able to investigate and describe, qualitatively, the phenomena of reflection, refraction, diffraction, and polarization of visible light.

Use the following information to answer question 40.

To demonstrate the polarization of light to a student, a teacher slowly rotated a polarizing filter  $360^\circ$  while keeping another identical polarizing filter stationary.



40. Which of the following rows shows the student's observations as the teacher rotates the filter?

Row	No Rotation ( $0^\circ$ )	1/4 Rotation ( $90^\circ$ )	1/2 Rotation ( $180^\circ$ )	3/4 Rotation ( $270^\circ$ )	1 Full Rotation ( $360^\circ$ )
A.					
B.					
C.					
D.					

The answer is C. Assessing C2.4k and C2.2s

Students should be able to identify different types of spectra and their sources. Students should also be aware that absorption spectra can be called dark-line spectra and that emission spectra can be called bright-line spectra.

Use the following information to answer question 41.

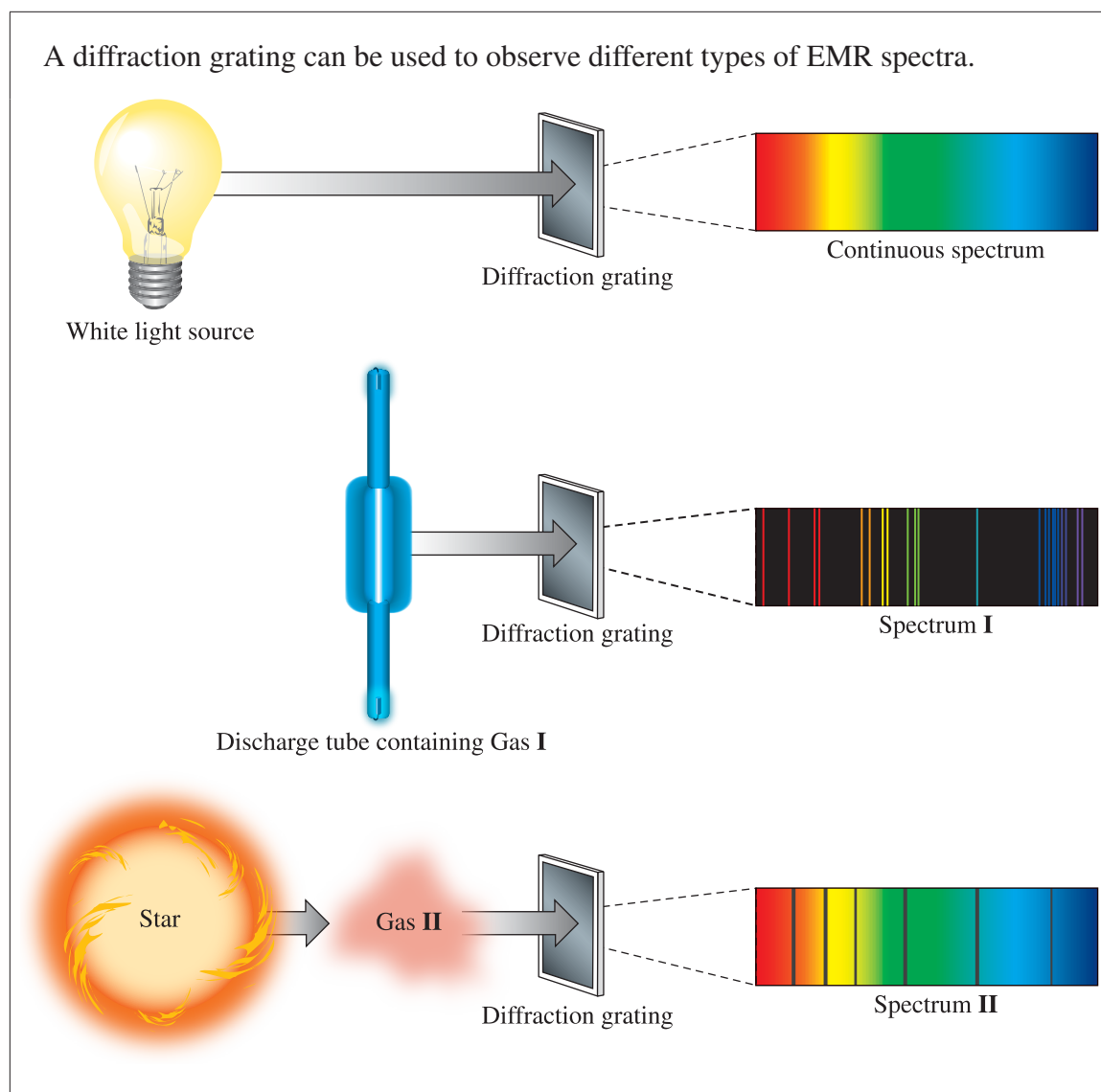

41. Which of the following rows classifies Spectrum I and identifies the relative temperature of Gas II compared to Gas I?

Row	Classification of Spectrum I	Relative Temperature of Gas II
A.	Absorption	Hotter than Gas I
B.	Absorption	Cooler than Gas I
C.	Emission	Hotter than Gas I
D.	Emission	Cooler than Gas I

The answer is D. Assessing C2.9k

A general knowledge of the evolution of stars is important.

*Use the following information to answer numerical-response question 42.*

**Some Stages in the Evolution of a Small Star**

- 1** Fusion begins
- 2** White dwarf
- 3** Red giant

**Numerical Response**

**42.** As a low-mass star, such as the Sun, evolves from a collection of gas and dust, the sequence in which the stages numbered above occur is \_\_\_\_\_, \_\_\_\_\_, and \_\_\_\_\_.

(Record all **three digits** of your answer in the numerical-response section on the answer sheet.)

The answer is 132. Assessing C2.11k

## Unit D, General Outcome 1

Students will explain the need for balancing the growth in global energy demand with maintaining a viable biosphere.

Global energy issues are the focus of this unit. Specific examples of solutions to problems need to be incorporated into the discussion of these issues, including the concept of sustainable development. Students should be able to interpret graphs and tables to describe trends in global energy use.

Students should be able to classify sources of energy as renewable or non-renewable. Renewable energy is derived from natural processes that are constantly replenished. Renewable energy comes directly from the Sun or from heat generated deep within Earth. Sources of renewable energy are EMR from the Sun, wind, movement of oceans (tidal and wave), flowing water in rivers and streams (hydro), heat from within Earth (geothermal), and biomass. Hydrogen and other fuels can be considered renewable if they are produced using renewable sources. Fossil fuels and fissionable atoms are not considered renewable sources of energy. The reactants for nuclear fusion are so plentiful in sea water and Earth's crust that they have the potential to provide energy on a time span similar to the Sun; therefore, if nuclear fusion were to become a viable energy source, it would be considered renewable.

### Sample Questions

The pollutants described in Unit B are relevant to evaluating energy sources and technologies in Unit D, as shown in the next two questions.

43. Which of the following concerns is associated with emissions from coal-burning power plants?
- A. Increase in skin cancers due to chlorofluorocarbons
  - B. Biomagnification due to polychlorinated biphenyls
  - C. Heavy metal leaching due to acid deposition
  - D. Increased BOD due to organic waste runoff

The answer is C. Assessing D1.5k, B2.3k, B2.6k, B1.2sts, and D2.1sts

Use the following information to answer question 44.

Ethanol can be produced by fermenting grain and crop waste. The ethanol can be burned as a fuel in automobile engines.

44. When the ethanol described above is classified as an energy source, it is considered   *i*  . When the net carbon dioxide produced during the production and burning of the ethanol is compared to the net carbon dioxide produced during the production and burning of a fossil fuel, the net carbon dioxide released from the ethanol is   *ii*  .

The statements above are completed by the information in row

Row	<i>i</i>	<i>ii</i>
A.	renewable	greater
B.	renewable	less
C.	non-renewable	greater
D.	non-renewable	less

The answer is B. Assessing D1.4k, D2.4k, D2.1sts, B2.1sts

Generation of electricity as described in Unit C is relevant to the operation of technologies described in Unit D.

*Use the following information to answer question 45.*

**Actions That Can Affect Energy Use in Canada**

- I** Upgrading insulation in homes
- II** Converting vehicles to run on biofuels
- III** Obtaining fossil fuels from oil sands deposits
- IV** Providing rebates to consumers to lower the cost of gasoline
- V** Modifying cars so that less gasoline will be required per kilometre

- 45.** Two actions listed above that increase energy efficiency and therefore promote sustainable development are
- A.** I and II
  - B.** I and V
  - C.** II and III
  - D.** III and IV

The answer is B. Assessing D1.3k and D1.1sts

Methane gas may be discussed as a commonly used hydrocarbon (in the context of B2.2k), as a greenhouse gas that contributes to climate change (in the context of B2.3k), or as a biomass energy source (in the context of D2.4k).

*Use the following information to answer question 46.*

**Description of a Fuel Source**

- Main source of heating for homes in Alberta
- Combustion of the fuel produces greenhouse gases
- Can be renewable if collected from decomposing biomass
- Release of this fuel into the environment contributes to climate change

- 46.** The fuel source described above is
- A.** low-sulfur coal
  - B.** uranium ore
  - C.** methane
  - D.** ethanol

The answer is C. Assessing D1.5k and D2.3k

## Unit D, General Outcome 2

Students will describe the Sun as Earth's main source of energy and explain the functioning of some conventional and alternative technologies that convert solar, nuclear, tidal, and other energy sources into usable forms.

Students should be able to calculate the energy changes from balanced chemical combustion equations,  $\Delta_r H$ , using standard molar heat (enthalpies) of formation,  $\Delta_f H^\circ$ , for substances. Students are not required to balance chemical equations.

A clear understanding of the transformations of energy before its intended use is necessary to discuss efficiency. Mechanical energy is the sum of the potential and kinetic energy of an object or a system. For example, the mechanical energy of a hydroelectric turbine while the turbine operating is kinetic, so the energy transformations for this technology would be best represented as follows: solar radiant  $\rightarrow$  gravitational potential (water behind the dam)  $\rightarrow$  kinetic (spinning turbine)  $\rightarrow$  electrical (generator).

Students should be familiar with the main technologies used to convert radiant solar energy into useful forms of energy, including active solar heating, passive solar heating, and solar photovoltaic technologies. Active solar heating technologies include flat plate solar thermal collectors and evacuated tube solar collectors. Solar photovoltaic (PV) modules (sometimes referred to as solar PV panels) convert radiant energy from the Sun into electrical energy.

Students are required to debate the advantages, disadvantages, similarities between, and differences among various renewable and non-renewable energy-production technologies.

Nuclear fusion in this unit can be related to EMR outcome C2.8k. Students are required to understand that fission, fusion, and decay reactions release energy according to the mass–energy equivalency. Students should be able to use the formula  $\Delta E = \Delta mc^2$  to calculate the quantity of energy available in nuclear processes. Students should be able to use conservation of nucleons and conservation of charge to determine missing nucleons in nuclear reaction equations. Relative comparisons of the energy involved in nuclear reactions, chemical reactions, and phase changes are expected.

### Sample Questions

Students must be able to calculate the heat of combustion when provided with a balanced hydrocarbon combustion equation.

*Use the following information to answer numerical-response question 47.*

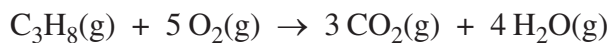

### Numerical Response

**47.** The energy released when one mole of  $\text{C}_3\text{H}_8(\text{g})$  burns is \_\_\_\_\_ kJ.

(Record your **four-digit answer** in the numerical-response section on the answer sheet.)

The answer is 2044. Assessing D2.1k and D2.3s

Students may be required to interpret analogies for phenomena.

**48.** In passive solar heating, the windows of a house have a function that is similar to that of

- A. infrared rays
- B. Earth's surface
- C. ultraviolet rays
- D. Earth's atmosphere

The answer is D. Assessing D2.4k

Students should be able to generally describe the advantages and disadvantages of both renewable and non-renewable energy technologies.

*Use the following information to answer question 49.*

A prolonged period of abnormally low precipitation resulting in a shortage of water is called a drought.

- 49.** Electricity-generating technologies that are likely to have decreased output due to a drought are
- A.** photovoltaic cells and tidal generating stations
  - B.** photovoltaic cells and hydroelectric generating stations
  - C.** biomass-burning power plants and tidal generating stations
  - D.** biomass-burning power plants and hydroelectric generating stations

The answer is D. Assessing D2.4k and D2.1sts

Students should recognize the energy conversion pathways for electrical-generating technologies that rely on different sources of energy.

Use the following information to answer question 50.

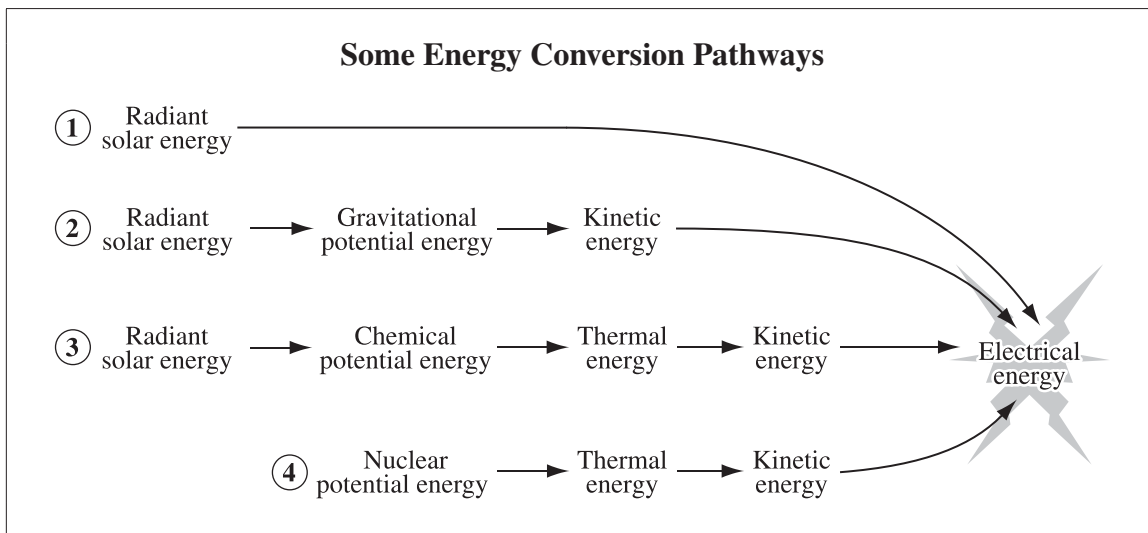

50. The production of electrical energy from photovoltaic panels is **most similar** to the pathway numbered

- A. 1
- B. 2
- C. 3
- D. 4

The answer is A. Assessing D2.3k

Students should be able to calculate the energy associated with a change in mass that occurs during a nuclear process.

*Use the following information to answer numerical-response question 51.*

The total mass of the products in a nuclear process is  $3.1 \times 10^{-2}$  kg less than the mass of the reactants.

### **Numerical Response**

- 51.** The energy released by the reaction, expressed in scientific notation, is  $a.b \times 10^{cd}$  J. The values of  $a$ ,  $b$ ,  $c$ , and  $d$  are  $\frac{\quad}{a}$ ,  $\frac{\quad}{b}$ ,  $\frac{\quad}{c}$ , and  $\frac{\quad}{d}$ .

(Record all **four digits** of your answer in the numerical-response section on the answer sheet.)

The answer is 2815. Assessing D2.7k and D2.3s

Data from previous diploma examinations indicate that students are much more successful when the change in mass is provided for nuclear reactions involving the equation  $\Delta E = \Delta mc^2$ , as shown in the previous sample question. In the next sample question, students must determine the change in mass and then apply  $\Delta E = \Delta mc^2$ . This question demonstrates the standard of excellence for this outcome.

*Use the following information to answer numerical-response question 52.*

**A Nuclear Reaction Equation**

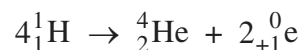

**Numerical Response**

- 52.** For the reaction represented above, when one mole of  $\text{}^4_2\text{He}$  is formed, the energy released is \_\_\_\_\_  $\times 10^{12}$  J.

(Record your **three-digit answer** in the numerical-response section on the answer sheet.)

The answer is 2.58. Assessing D2.3k

Students should be able to compare the processes of nuclear fusion and fission.

- 53.** One of the differences between nuclear fission and nuclear fusion is that
- A.** fission involves the splitting of nuclei, whereas fusion involves the joining of nuclei
  - B.** fusion involves the splitting of nuclei, whereas fission involves the joining of nuclei
  - C.** fission involves the absorption of energy, whereas fusion involves the release of energy
  - D.** fusion involves the absorption of energy, whereas fission involves the release of energy

The answer is A. Assessing D2.5k

Students should be able to classify a nuclear process as nuclear fission, nuclear fusion, alpha decay, beta decay, or gamma decay.

**54.** Which of the following equations represents a fission reaction that occurs in a nuclear power plant?

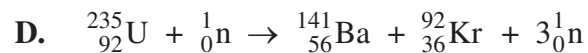
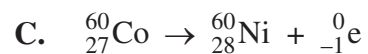
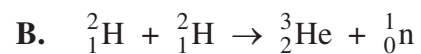
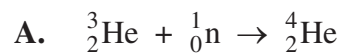

The answer is D. Assessing D2.5k, D2.6k, D2.8k

Use the following information to answer numerical-response question 55.

### Two Types of Radioactive Decay

- 1 Alpha decay
- 2 Beta decay

### Numerical Response

- 55.** Match a type of radioactive decay numbered above with each equation listed below. Numbers may be used more than once.



(Record your answer in the numerical-response section on the answer sheet.)

The answer is 1221. Assessing D2.6k



Students should be able to explain the source of tides in terms of the relative motions of the Sun, Earth, and the Moon.

57. Which of the following rows **most accurately** illustrates how Earth’s ocean tides are affected by the relative positions of the Moon and the Sun?









Row	New Moon	First Quarter	Full Moon	Last Quarter
A.				
B.				
C.				
D.				

The answer is D. Assessing D2.12k

## WHMIS 2015

The Workplace Hazardous Materials Information System (WHMIS) has been used in Canada since 1988 for the labelling and classification of hazardous workplace chemicals. The Globally Harmonized System of Classification and Labelling of Chemicals (GHS) is being adopted by countries around the world in order to enable a consistent international chemical classification and labelling system. In Canada, WHMIS 1988 was amended in February 2015 to incorporate the GHS.

Any WHMIS pictograms that appear on provincial assessments will be WHMIS 2015 pictograms.

<b>WHMIS 2015</b>		
<p><b>Flame</b></p>  <p>For fire hazards</p>	<p><b>Flame Over Circle</b></p>  <p>For oxidizing hazards</p>	<p><b>Gas Cylinder</b></p>  <p>For gases under pressure</p>
<p><b>Exploding Bomb</b></p>  <p>For explosion or reactivity hazards</p>	<p><b>Biohazardous Infectious Materials</b></p>  <p>For organisms or toxins that can cause diseases in people or animals</p>	<p><b>Corrosion</b></p>  <p>For corrosive damage to metals, as well as skin, eyes</p>
<p><b>Exclamation Mark</b></p>  <p>May cause less serious health effects</p>	<p><b>Health Hazard</b></p>  <p>May cause or suspected of causing serious health effects</p>	<p><b>Skull and Crossbones</b></p>  <p>Can cause death or toxicity with short exposure to small amounts</p>



## Development of Textbook Resources to Support the Program of Studies

The current Science 30 Program of Studies was implemented in 2007–2008. Alberta Education and Childcare has developed the following resources to support the Science 20 and 30 programs (only in English):

- *Science 30: Student Textbook* (includes CD-ROMs), 2007
- *Science 30: Teacher Resource Guide* on CD-ROM, 2007

The student textbook was authored by Science 30 teachers in Alberta and published by Alberta Education and Childcare. The student textbook contains two CDs with multimedia segments, digital activities supporting related ICT outcomes, detailed answer keys to support textbook activities, digital copies of handouts, and a folder for students involved in alternative learning environments such as distance learning, blended programs, and virtual school programs.

A digital *Science 30 Teacher Resource Guide* is also available and includes support for assessment. Teachers are able to print from the PDF documents or customize the HTML versions provided. This digital resource includes a distance learning teacher guide folder to support teachers instructing in that environment.



## Publications and Supporting Documents

In addition to this Information Bulletin, the following documents are published by Alberta Education and Childcare and are available on the [Writing diploma exams](#) web page:

- *Science 30 Student-based Performance Standards*
- *Science 30 Released Items*
- *Examples of Descriptions Used in Audio Versions of Science Diploma Exams*
- *2025–2026 Calculator Information and Rules for Mathematics and Science Diploma Exams*
- *A Guide for Students Preparing to Write the Diploma Examination:  
Biology 30 / Chemistry 30 / Physics 30 / Science 30*

---

## Website Links

[Alberta Education and Childcare](#) website

[Programs of study](#)

[General Information Bulletin](#)

contains specific directives, guidelines, and procedures of diploma examinations

[Diploma exams](#)

[Writing diploma exams](#)

contains Guides for Students, exemplars, and other support documents

[Quest A+](#)

contains practice questions and questions from previous diploma examinations

[Digital Assessment Platform](#)

contains practice questions and questions from previous diploma examinations

**\*NEW** [Help page](#)

contains guides to help users of digital assessments access and administer secured tests and exams

[Field Test Information](#)

[Teacher participation in provincial assessments](#)

contains information about marking, field testing, item development, and examination validation

[School Reports and Instructional Group Reports](#)

contain detailed statistical information on provincial, group, and individual student performance on the entire examination

# Contacts 2025–2026

## Provincial Assessment

Provincial Assessment,  
Alberta Education and Childcare  
44 Capital Boulevard  
10044 108 Street NW  
Edmonton AB T5J 5E6

Alberta Education and Childcare website: [alberta.ca/education-and-childcare](https://alberta.ca/education-and-childcare)

## Provincial Assessment

### Diploma exam security, diploma exam rules, scheduling, and policy issues

780-427-1857

Email: [exam.admin@gov.ab.ca](mailto:exam.admin@gov.ab.ca)

### Results statements and rescores

780-427-1857

Email: [exam.admin@gov.ab.ca](mailto:exam.admin@gov.ab.ca)

### Special cases, accommodations, and exemptions

780-415-9242

780-427-4215

780-427-9795

Email: [special.cases@gov.ab.ca](mailto:special.cases@gov.ab.ca)

### Field testing

Email: [field.test@gov.ab.ca](mailto:field.test@gov.ab.ca)

### Diploma exam format, content, confirming standards, marking, and results reporting

Email: [diploma.exams@gov.ab.ca](mailto:diploma.exams@gov.ab.ca)

### French Assessment

Email: [french.assessment@gov.ab.ca](mailto:french.assessment@gov.ab.ca)

### Digital Assessment

780-641-8987

780-415-0824

Email: [online.assessment@gov.ab.ca](mailto:online.assessment@gov.ab.ca)

### myPass Access

#### Alberta Education and Childcare Help Desk

780-427-5318

Email: [AE.helpdesk@gov.ab.ca](mailto:AE.helpdesk@gov.ab.ca)

### Inquiries about transcripts, credentials, detailed academic reports, and rewrite fees

780-427-5732

Email: [studentrecords@gov.ab.ca](mailto:studentrecords@gov.ab.ca)

### Inquiries about student enrollment and marks and mature student status

780-422-9337

Email: [studentrecords@gov.ab.ca](mailto:studentrecords@gov.ab.ca)

### Packing and shipping of test materials

780-427-1857

Email: [exam.admin@gov.ab.ca](mailto:exam.admin@gov.ab.ca)

For a toll-free call to any Alberta government office, dial 310-0000 followed by the 10-digit phone number of the office that you would like to reach.

When contacting Alberta Education and Childcare, please include your name, title, school name, school code, and, if referring to a student, include the student's Alberta Student Number.

---

## Contacts 2025–2026

### Diploma Programs

**\*NEW**

**Terri Lynn Mundorf, Director**

Diploma Programs  
780-422-0206  
Email: [Terri-Lynn.Mundorf@gov.ab.ca](mailto:Terri-Lynn.Mundorf@gov.ab.ca)

### French Assessment and Canadian Adult Education Credential

**Corey Baker, Director**

French Assessment and  
Canadian Adult Education Credential  
780-422-3256  
Email: [Corey.Baker@gov.ab.ca](mailto:Corey.Baker@gov.ab.ca)

### Diploma Exam Leads

**Nathalie Langstaedtler,  
Senior Manager of Humanities**

Diploma Programs  
780-422-4631  
Email: [Nathalie.Langstaedtler@gov.ab.ca](mailto:Nathalie.Langstaedtler@gov.ab.ca)

**Philip Taranger**

English Language Arts 30–1  
780-422-4478  
Email: [Philip.Taranger@gov.ab.ca](mailto:Philip.Taranger@gov.ab.ca)

**Keri Helgren**

English Language Arts 30–2  
780-422-5213  
Email: [Keri.Helgren@gov.ab.ca](mailto:Keri.Helgren@gov.ab.ca)

**Charla Jo Guillaume**

Social Studies 30–1  
780-422-5241  
Email: [Charlajo.Guillaume@gov.ab.ca](mailto:Charlajo.Guillaume@gov.ab.ca)

**Lisa Lemoine**

Social Studies 30–2  
780-422-4327  
Email: [Lisa.Lemoine@gov.ab.ca](mailto:Lisa.Lemoine@gov.ab.ca)

**Gwendolyn Shone,  
Manager of French Assessment**

French Assessment and  
Canadian Adult Education Credential  
780-422-5464  
Email: [Gwendolyn.Shone@gov.ab.ca](mailto:Gwendolyn.Shone@gov.ab.ca)

**Frédéric Sévigny**

Français 30–1, French Language Arts 30–1  
780-422-5140  
Email: [Frederic.Sevigny@gov.ab.ca](mailto:Frederic.Sevigny@gov.ab.ca)

**Joy Wicks,  
Senior Manager of Math and Sciences**

Diploma Programs  
780-643-6716  
Email: [Joy.Wicks@gov.ab.ca](mailto:Joy.Wicks@gov.ab.ca)

**Shannon Mitchell**

Biology 30  
780-415-6122  
Email: [Shannon.Mitchell@gov.ab.ca](mailto:Shannon.Mitchell@gov.ab.ca)

**Brenda Elder**

Chemistry 30  
780-427-1573  
Email: [Brenda.Elder@gov.ab.ca](mailto:Brenda.Elder@gov.ab.ca)

**Delcy Rolheiser**

Mathematics 30–1  
780-415-6181  
Email: [Delcy.Rolheiser@gov.ab.ca](mailto:Delcy.Rolheiser@gov.ab.ca)

**Jenny Kim**

Mathematics 30–2  
780-415-6127  
Email: [Jenny.Kim@gov.ab.ca](mailto:Jenny.Kim@gov.ab.ca)

**Marc Kozak**

Physics 30  
780-422-5465  
Email: [Marc.Kozak@gov.ab.ca](mailto:Marc.Kozak@gov.ab.ca)

**Stan Bissell**

Science 30  
780-422-5730  
Email: [Stan.Bissell@gov.ab.ca](mailto:Stan.Bissell@gov.ab.ca)