



# Information Bulletin Physics 30

Diploma Examinations Program **2025–2026**

---

**This document was primarily written for:**

Students

Teachers  of Physics 30

Administrators

Parents

General Audiences

Others

---

***2025–2026 Physics 30 Information Bulletin***

Distribution: This document is posted on the [Alberta Education and Childcare](#) website.

Copyright © 2025, the Crown in Right of Alberta, as represented by the Minister of Education and Childcare, Alberta Education and Childcare, Provincial Assessment, 6th floor, 44 Capital Boulevard, 10044 108 Street NW, Edmonton, Alberta T5J 5E6, and its licensors. All rights reserved.

**Special permission** is granted to **Alberta educators only** to reproduce, for educational purposes and on a non-profit basis, parts of this document that do **not** contain excerpted material.

Excerpted material in this document **shall not** be reproduced without the written permission of the original publisher (see credits, where applicable).

# Contents

Introduction.....	1
Examination Security.....	2
Time Limits on Diploma Examinations.....	2
Equating to Maintain Consistent Standards over Time on Diploma Examinations .....	3
Diploma Examinations: Multiple Forms .....	4
How to Get Involved.....	5
Field Testing .....	6
· How do field tests help teachers and students?	6
· How are field-test data used?	6
· Science field tests	6
· How can teachers schedule field tests?	7
Physics 30 Field Testing.....	8
Practice Tests.....	9
Special-format Practice Tests .....	9
Audio Descriptions .....	9
Course Objectives .....	10
Cognitive Expectations in the Program of Studies .....	11
Questions Illustrating Various Cognitive Levels .....	12
Performance Expectations .....	14
· Curriculum standards	14
· Acceptable standard	14
· Standard of excellence	14
Examination Specifications and Design .....	15
· Program of studies outcomes	15
Constants .....	17
<i>Physics 30 Diploma Examination</i> Instructions Pages: Paper Format.....	18
<i>Physics 30 Diploma Examination</i> Instructions Page: Digital Format.....	22
Physics 30 Data Pages.....	23

<b>Using Calculators.....</b>	<b>26</b>
<b>Assessment of Skills and STS Connections .....</b>	<b>27</b>
<b>Illustrative Graphing Skills .....</b>	<b>28</b>
<b>Illustrative Numerical-response Items Assessing Mandated Skills.....</b>	<b>30</b>
<b>Illustrative Items from Field Testing or Diploma Examinations</b>	
<b>Showing Word Usage and Exploring Misconceptions.....</b>	<b>40</b>
<b>Trends in Student Performance.....</b>	<b>49</b>
· Comments relating to general skills outcomes	49
· Comments relating to specific knowledge outcomes	49
· Comments on conservation of energy	50
· Physics principles	51
<b>Clarifications .....</b>	<b>52</b>
· Expectations that span all the general outcomes	52
· Specific outcomes for skills	52
· Sign conventions	53
· Specific outcomes for STS	53
· Specific outcomes for Knowledge	54
· General Outcome A: Momentum and Impulse	54
· General Outcome B: Forces and Fields	54
· General Outcome C: Electromagnetic Radiation	55
· General Outcome D: Atomic Physics	56
<b>Publications and Supporting Documents.....</b>	<b>58</b>
<b>Website Links .....</b>	<b>59</b>
<b>Contacts 2025–2026.....</b>	<b>60</b>

Please note that if you cannot access one of the direct website links referred to in this document, you can find diploma examination-related materials on the [Alberta Education and Childcare](#) website.



## Introduction

The purpose of this bulletin is to provide teachers of Physics 30 with information about the diploma examinations scheduled in the 2025–2026 school year. This bulletin should be used in conjunction with the current [Physics 20–30 Program of Studies 2007 \(Updated 2014\)](#).

This bulletin includes descriptions of the *Physics 30 Diploma Examinations* that will be administered in November of 2025 and in January, April, June, and August of 2026; descriptions of the acceptable standard and the standard of excellence; subject-specific information; and some illustrative sample questions.

The mark awarded to a student on the *Physics 30 Diploma Examination* in the 2025–2026 school year will account for 30% of the student’s final blended mark, and the school-awarded mark will account for the remaining 70%.

Teachers are encouraged to share the contents of this bulletin with students.

For further information about program implementation, refer to the [Alberta Education and Childcare](#) website.

---

## Examination Security

All diploma examinations will be held secure until they are released to the public by the Minister. No secure diploma examination is to be viewed until it is released to the public by the Minister. No secure diploma examination is to be previewed, discussed, copied, or removed from the room in which the examination is being written. However, for the January and June administrations only, teachers will be allowed access to a teacher perusal copy for review purposes 1 hour after the examination has started.

For mathematics and science diploma examinations, all diploma examinations must be kept secure before, during, and after administration, without exception.

For humanities diploma examinations, the humanities *Part A: Written Response* examinations in the January and June administrations must be kept secure until after they are administered. All other humanities *Part A: Written Response* examinations, and all humanities *Part B* examinations, must be kept secure before, during, and after administration, without exception.

Unused copies of all secured diploma examinations must be returned to Alberta Education and Childcare as per the dates indicated in the [Significant Dates at-a-Glance](#) resource.

For more information about teacher perusal copies and examination security, please refer to the [Administering diploma exams](#) web page.

---

## Time Limits on Diploma Examinations

All students may use extra time to write diploma examinations. This means that all students have up to 6 hours to complete the *Physics 30 Diploma Examination*, if they need it. The examination is nevertheless designed so that the majority of students can complete it within 3 hours. The examination instructions state both the designed time and the total time allowed.

Although extra time is allowed for diploma examinations in all subjects, the total time allowed is not the same in all subjects. For more information about accommodations and provisions for students, please refer to the [Administering diploma exams](#) web page.

---

## Equating to Maintain Consistent Standards over Time on Diploma Examinations

A goal of Alberta Education and Childcare is to make scores achieved on examinations within the same subject directly comparable from session to session, to ensure fairness to students across administrations.

To achieve this goal, the examination has a number of questions in common with a previous examination. Common (anchor) items are used to find out if the student population writing in one administration differs in achievement from the student population writing in another administration. Common items are also used to find out if the unique items (questions that have never appeared in a previous examination) differ in difficulty from the unique (non-anchor) items on the baseline examination that sets the standard to which all students are held.

A statistical process called equating adjusts for differences in difficulty between examinations. Examination marks may be adjusted depending upon the difficulty of the examination written relative to the baseline examination. Therefore, the resulting equated examination scores have the same meaning regardless of when and to whom the examination was administered. Equated diploma examination marks are reported to students. More information about equating is available on the [Administering diploma exams](#) web page.

Because of the security required to ensure fair and appropriate assessment of student achievement over time, *Physics 30 Diploma Examinations* will be fully secured and will not be released at the time of writing.



## Diploma Examinations: Multiple Forms

Some subjects may have two distinct forms (versions) of diploma examinations during major administrations (January and June). Like all other diploma examinations, the two forms are equated to the baseline examination to ensure that the same standard applies to both forms. Both forms adhere to the established blueprint specifications and are reviewed by a technical review committee.

To facilitate the analysis of school-level results, each school receives only one examination form per subject. In subjects offering a translated French-language examination, both forms are administered in English and in French.

### **For more information, contact the following:**

Diploma exam format, content, confirming standards,  
marking, and results reporting

[Diploma.Exams@gov.ab.ca](mailto:Diploma.Exams@gov.ab.ca)

or

French Assessment

[French.Assessment@gov.ab.ca](mailto:French.Assessment@gov.ab.ca)

or

Diploma exam security, diploma exam rules,  
scheduling, and policy issues

[Exam.Admin@gov.ab.ca](mailto:Exam.Admin@gov.ab.ca)



## How to Get Involved

High-quality diploma examinations are the product of close collaboration between classroom teachers and Alberta Education and Childcare. Classroom teachers from across Alberta are involved in many aspects of diploma examination development, including the development of items; the building, reviewing, administering, and marking of field tests; the reviewing and validating of diploma examinations; the reviewing of support documents; and the marking of diploma examinations.

The development of test items from when they are written until when they appear on an examination takes at least one year. All items on the *Physics 30 Diploma Examinations* are written and/or validated by Physics 30 teachers from across Alberta. After provincial implementation of the program of studies, items are field tested to ensure their reliability and validity. Diploma examinations are reviewed by editors, teachers, academic experts, curriculum staff, translators, and a French validation working group.

Alberta Education and Childcare values the involvement of teachers and annually asks school authorities for the names of teachers who are interested in being involved in any of the development processes for diploma examinations. Teachers who are interested in developing items, constructing field tests, or reviewing and validating examinations are encouraged to talk to their principals about how they can submit their names for approval to be involved in these processes. Although the call for submissions for working groups occurs each fall, teachers are welcome to have their names submitted at any time.

## Field Testing

Field testing is an essential stage in the development of fair, valid, and reliable provincial examinations. Field testing is a process of collecting data on questions before the questions become part of a diploma examination. Potential diploma examination questions are administered to students in field tests for diploma courses throughout the province to determine the difficulty and appropriateness of the questions. Each field test requires a large student sample to provide the examination developers with reliable information (i.e., statistical data and written validation comments from teachers and students).

### How do field tests help teachers and students?

Teachers receive each student's score promptly, gaining useful information about their students' performance. Students benefit from writing a test that duplicates some of the experience of writing a diploma examination. Field tests provide students and teachers with examples of the format and content of questions that may appear on diploma examinations. Finally, because of field testing, students, teachers, and parents can be reassured that the questions on diploma examinations have undergone a rigorous development, improvement, and validation process.

### How are field-test data used?

The data received from field tests indicate the validity, reliability, and fairness of each question. Questions that meet specific standards are selected for use on future diploma examinations.

Some questions or sets of questions may not initially perform as well as we require. These questions may be revised and tested again in field tests. Revisions are influenced by the written comments of students and teachers, who provide valuable advice about the appropriateness of the questions, the adequacy of writing-time limits, test length, text readability, artwork/graphics clarity and suitability, and question difficulty.

### Science field tests

Science field tests are available in digital format on the digital assessment platform.

Students may use paper data booklets or data pages for all science field tests. These resources will also appear in the digital assessment platform. Students should have scrap paper, which may be accessed in the "Forms" section on the [Administering diploma exams](#) web page. All paper data sheets and scrap paper with markings must be securely shredded at the end of the field-test administration.

Teachers are provided with data on how their students performed. Test items address learning outcomes in the program of studies, which allows teachers to use field-test results to learn more about their students' strengths and areas for improvement.

The security of field-test items remains vital to the administration of diploma examinations. Participating teachers must commit to maintaining the security of field-test items.

More information about field-test registration deadlines, administration, and security is available in the *Field Testing Guide 2025–2026* on the [Teacher participation in provincial assessments](#) web page.

## How can teachers schedule field tests?

Field tests are offered digitally on the digital assessment platform. To schedule a field test, teachers must have a digital assessment platform teacher account.

For information about how to schedule and administer a field test, please refer to the *Field Testing Guide 2025–2026* on the [Teacher participation in provincial assessments](#) web page or contact [Field.Test@gov.ab.ca](mailto:Field.Test@gov.ab.ca).

Detailed instructions for how to schedule a field test can also be found on the digital assessment platform [Help](#) web page.

### For more information, contact the following:

Diploma exam format, content, confirming standards,  
marking, and results reporting  
[Diploma.Exams@gov.ab.ca](mailto:Diploma.Exams@gov.ab.ca)

or

French Assessment  
[French.Assessment@gov.ab.ca](mailto:French.Assessment@gov.ab.ca)

or

Diploma exam security, diploma exam rules,  
scheduling, and policy issues  
[Exam.Admin@gov.ab.ca](mailto:Exam.Admin@gov.ab.ca)

## Physics 30 Field Testing

The Physics 30 program is thankful to the many teachers and students who have volunteered for field test placements. The table below shows the format, number of questions, and length of time for field tests available for the 2025–2026 school year. Teachers may wish to consider this table when requesting a field-test placement.

Physics 30 field tests are offered in digital format.

The table below shows the number of questions and length of time for field tests available for the 2025–2026 school year. Teachers may wish to consider this table when requesting a field test placement.

	Unit Test	End-of-course Test
Number of questions	11–15	13–20
Test time (min)	50*	50 or 70*

\*The field tests are designed to be completed in the time specified; however, an additional 15 minutes may be used, if available. These time instructions appear on the field test instructions pages.

Type of Field Test	
Unit test	Unit A Unit B Unit C Unit D
End-of-course	All units

Students are expected to use paper copies of the data sheets when writing field tests, and teachers should ensure that their class has sufficient unmarked data sheets available for the testing session.

Field tests can be scheduled either within class time or outside class time up to the day before the *Physics 30 Diploma Examination*.

As the capability of the [digital assessment platform](#) expands, teachers should expect to see changes to certain questions commonly used in field testing. One example is the question found at the end of the *Physics 30 Diploma Examination* that tasks students with selecting two physics principles used to answer a multi-step calculation. An example of a format used for this question can be found in the Physics 30 Practice Test in the [digital assessment platform](#). For the 2025–2026 school year, the Physics 30 field testing program will be field testing a different format of this question than the one that appears in the practice test in the [digital assessment platform](#).

For more information on requesting field tests, please refer to the [Field Testing Program Rules, Procedures and Request Guide](#).

---

## Practice Tests

To give students an opportunity to practise answering questions similar to those used on diploma examinations that address learning outcomes in the program of studies, Alberta Education and Childcare produces practice tests for subjects that have a diploma examination. Students can access these practice tests using Alberta Education and Childcare's [digital assessment platform](#).

---

## Special-format Practice Tests

To give students an opportunity to practise answering questions similar to those used on diploma examinations that address learning outcomes in the program of studies in Braille, large print, or coloured print versions, Alberta Education and Childcare produces special-format practice tests for all subjects that have a diploma examination. Alberta schools with registered Alberta K–12 students may place orders for these tests. Braille versions are available in English and, by request, in French. All tests are provided free of charge, but limits may be placed on order volumes to ensure access for all students.

For the greatest benefit, special-format practice tests should be written under conditions similar to those of the corresponding diploma examination. The same rules regarding the use of resources and devices should be followed.

Braille versions must be returned to Alberta Education and Childcare after use.

For more information or to place an order, contact [Field.Test@gov.ab.ca](mailto:Field.Test@gov.ab.ca).

---

## Audio Descriptions

A support document, [Examples of Descriptions Used in Audio Versions of Science Diploma Exams](#), has been developed to assist teachers and students planning to use an audio version during the administration of a science diploma examination.



## Course Objectives

Physics 30 is intended to further students' understanding and application of fundamental physics concepts and skills. The focus of the course is on understanding the physics principles behind the natural events that students experience and the technology that they use in their daily lives. The course encourages enthusiasm for the scientific enterprise and develops positive attitudes about physics as an interesting human activity with personal meaning. It develops knowledge, skills, and attitudes to help students become capable of and committed to setting goals, making informed choices, and acting in ways that will improve their own lives as well as life in their communities.

To develop the required knowledge, skills, and attitudes in Physics 30, students must have successfully completed Science 10 and Physics 20.

Although there is no mathematics prerequisite for Physics 30, students who have successfully completed Mathematics 20–1 or Mathematics 20–2 will have better algebra skills to use in the course.

# Cognitive Expectations in the Program of Studies

Outcomes in the Physics 30 Program of Studies contain verbs that indicate the cognitive expectations of the outcome. Verbs typically classified as remembering and understanding (R/U) are coded yellow in the chart below; verbs typically classified as applying (A) are coded green; verbs typically classified as higher mental activities (HMA) are coded blue; and those relating to skills are coded pink.

The following graphic shows the information arranged in a hierarchy, which is the arrangement used in the revised Bloom's taxonomy. The graphic is used fairly consistently in the four diploma examinations that assess science: Biology 30, Chemistry 30, Physics 30, and Science 30.

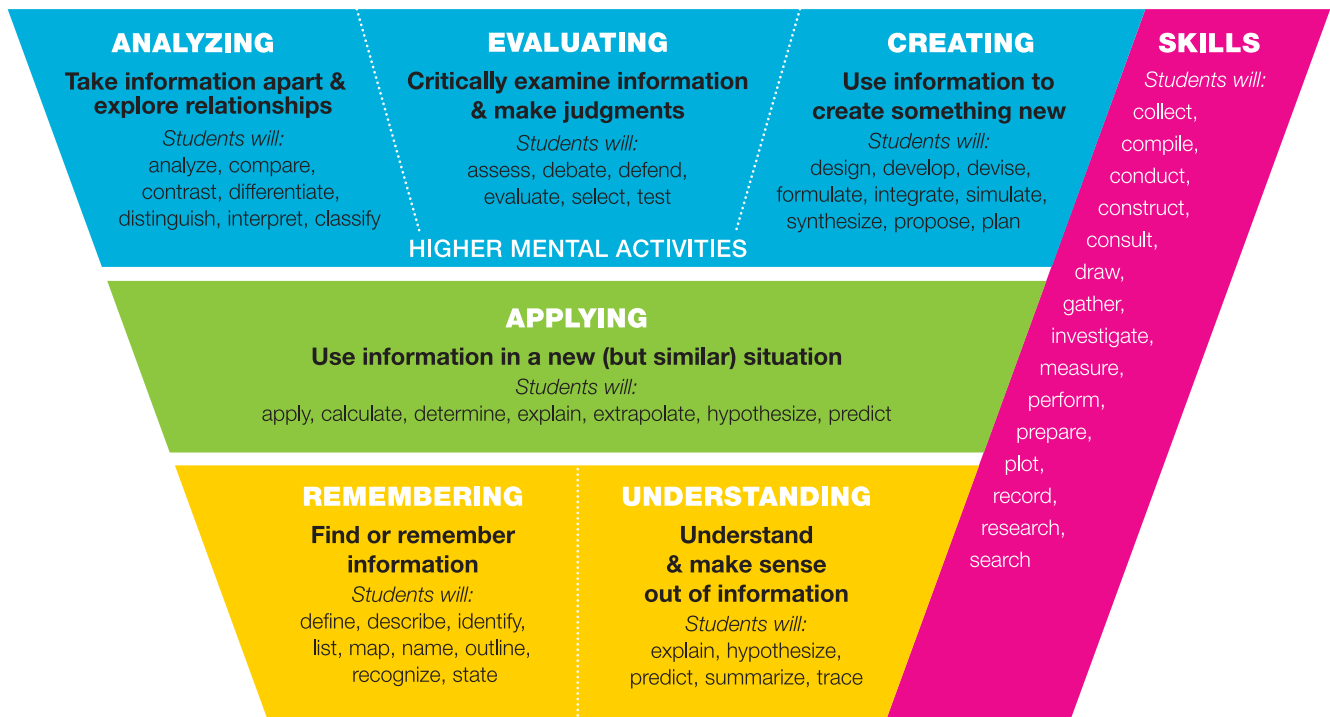

\*Verbs can have multiple connotations and can therefore indicate more than one cognitive level. The cognitive expectation is communicated by the context. —based on Anderson, Krathwohl, and Bloom, 2001.

The verbs arranged in the graphic shown above are only those that have been used in the Physics 30 Program of Studies. Remember that the graphic should serve only as a guideline and that the verbs are not permanently fixed in the categories shown. A verb can indicate a variety of cognitive levels depending on the context in which it is used; the verb and the context together are what determines the cognitive expectation.

Note that difficulty is independent of cognitive level. Outcomes at any of the cognitive levels can be assessed at either the acceptable standard or the standard of excellence.

## Questions Illustrating Various Cognitive Levels

This group of three items shows how outcome C2.6k can be tested at a remembering and understanding level (R/U), an application level (A), and a higher mental activity level (HMA).

Students achieving the standard of excellence need to be given the opportunity to show their true ability on HMA-level tasks.

*Use the following information to answer questions 9 and 10 and numerical-response question 8.*

In a Compton scattering event, an incident photon that has an energy of  $2.0 \times 10^{-14} \text{ J}$  is directed toward a carbon target. The scattered photon is detected, having been deflected through an angle of  $133^\circ$ , as shown below.

### A Compton Scattering Event

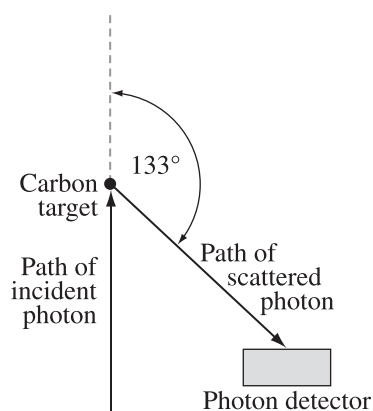

The scattering event can be analyzed to compare the incident and scattered photons, and to determine the predicted path of the scattered electron.

9. Which of the following rows correctly compares the characteristics of the scattered photon to those of the incident photon?

Row	Wavelength or Frequency	Speed or Momentum
A.	The scattered wavelength is longer.	The scattered speed is slower.
B.	The scattered wavelength is longer.	The scattered momentum is less.
C.	The scattered frequency is higher.	The scattered speed is slower.
D.	The scattered frequency is higher.	The scattered momentum is less.

The answer is B.

## Numerical Response

8. The wavelength of the scattered photon, expressed in scientific notation, is  $a.b \times 10^{-cd}$  m. The values of  $a$ ,  $b$ ,  $c$ , and  $d$  are \_\_\_\_\_, \_\_\_\_\_, \_\_\_\_\_, and \_\_\_\_\_.

(Record all **four digits** of your answer in the response area at the bottom of the screen.)

Answer: 1411

10. Which of the following diagrams **most accurately** represents the predicted path of the scattered electron?

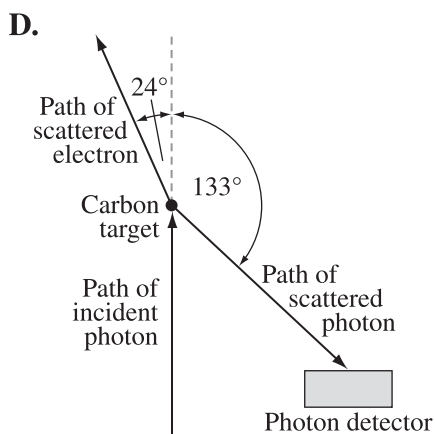
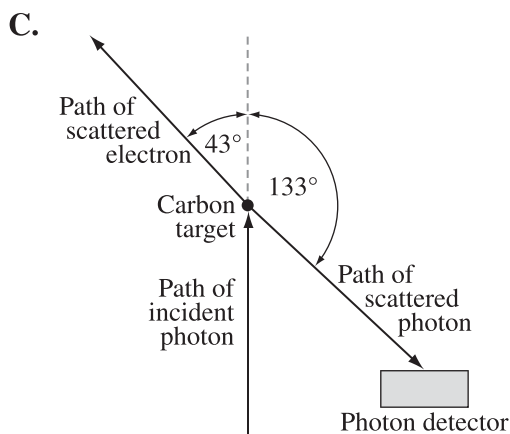
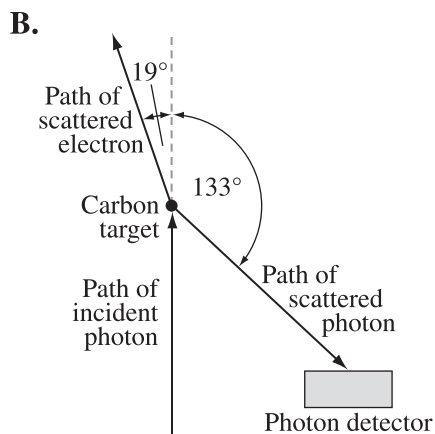
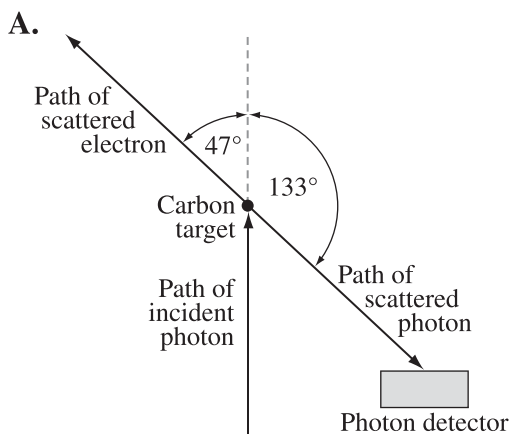

The answer is B.

# Performance Expectations

## Curriculum standards

Provincial curriculum standards help to communicate how well students need to perform in order to achieve the objectives specified in the [Physics 20–30 Program of Studies 2007 \(Updated 2014\)](#). The specific statements of standards are written primarily to advise Physics 30 teachers of the extent to which students must know the Physics 30 content and be able to demonstrate the required skills in order to pass the diploma examination.

Diploma exams are designed to match the program of studies of each subject, but what the diploma exams measure may not be the same in scope as what teachers measure. Diploma exam marks and teacher-awarded marks should reflect the same standard, however, because both assess students based on the same program of studies (curriculum). Alberta Education and Childcare works with teachers to set and maintain the standards of achievement for diploma exams. This information bulletin is intended to assist teachers in understanding the provincial standards for Physics 30.

## Acceptable standard

Students who achieve the acceptable standard in Physics 30 will receive a final course mark of 50% or higher. Students achieving the acceptable standard have gained new skills and knowledge in physics but may encounter difficulties if they choose to enroll in post-secondary physics courses. These students are able to define basic physics terms and are able to state and use formulas as they appear on the equation sheet. They can do this in situations where they need to sort through a limited amount of information. Their laboratory skills are limited to following explicit directions and to using laboratory data to verify known physics information. They are able to identify manipulated and responding variables but may experience difficulty identifying relevant controlled variables. These students are able to relate graph shape to memorized relationships but may experience difficulties analyzing non-linear graph shapes. These students tend to use item-specific methods in their problem solving and experience difficulty applying physics principles as a framework for their solutions. When explaining the connections between science, technology, and society, these students tend to use examples provided from textbooks. These students may have difficulty connecting physics to real-life scenarios beyond the classroom.

## Standard of excellence

Students who achieve the standard of excellence in Physics 30 receive a final course mark of 80% or higher. They have demonstrated their ability and interest in both mathematics and physics and feel confident about their scientific abilities. These students should encounter little difficulty in post-secondary physics programs and should be encouraged to pursue careers in which they will utilize their talents in physics. Students who achieve the standard of excellence show flexibility and creativity when solving problems, and changes in problem format do not cause them major difficulties. They seek general methods to solve problems and are confident using physics principles as a framework for their solutions. In the laboratory, students who achieve the standard of excellence can interpret data that are less than perfect or with instructions that are incomplete. These students are able to explicitly relate graph shape to mathematical models and to physics equations. They transfer knowledge from one area of physics to another and can express their answers in clear and concise terms. These students are able to apply cause-and-effect logic in a variety of situations: algebraically, experimentally, etc. In addition, these students can connect their understanding of physics to real-world situations that include technological applications and implications beyond the classroom setting.

A document that describes standards of achievement appropriate to the [Physics 20–30 Program of Studies 2007 \(Updated 2014\)](#) can be found on the Alberta Education and Childcare website. *The Student-Based Performance Standards* document provides examples of some behaviours exhibited by students at the acceptable standard and at the standard of excellence. It should be used in conjunction with the program of studies, as it is not intended to replace the program of studies. The *Student-Based Performance Standards* document is posted on the [Writing diploma exams](#) web page.

# Examination Specifications and Design

Each *Physics 30 Diploma Examination* is constructed as closely as possible to the following specifications.

## Program of studies outcomes

The design supports the integration of all Physics 30 general outcomes (GOs) as mandated in the [Physics 20–30 Program of Studies 2007 \(Updated 2014\)](#).

Adjustments in the emphasis may be necessary because the examination includes machine-scored scenarios or contexts that cover more than one general outcome. As a result, the examination is not necessarily arranged sequentially by units but is instead built around scenarios or contexts that support science, technology, and society (STS) connections. A set of questions may assess students' ability to integrate several GOs.

---

General Outcomes	Areas of Study	Emphasis
<b>GO A</b>	<b>Momentum and Impulse</b> Students will explain how momentum is conserved when objects interact in an isolated system.	<b>10–20%</b>
<b>GO B</b>	<b>Forces and Fields</b> Students will explain the behaviour of electric charges, using the laws that govern electrical interactions. They will describe electrical phenomena, using the electric field theory. They will explain how the properties of electric and magnetic fields are applied in numerous devices.	<b>25–35%</b>
<b>GO C</b>	<b>Electromagnetic Radiation</b> Students will explain the nature and behaviour of EMR, using the wave model. They will explain the photoelectric effect, using the quantum model.	<b>25–35%</b>
<b>GO D</b>	<b>Atomic Physics</b> Students will describe the electrical nature of the atom. They will describe the quantization of energy in atoms and nuclei. They will describe nuclear fission and fusion as powerful energy sources in nature. They will describe the ongoing development of models of the structure of matter.	<b>20–30%</b>

---

Questions on the diploma examination will require students to demonstrate knowledge of physics concepts and to apply skills in a context that supports making STS connections.

---

**Scientific Process and Communication Skills**

Students will

- formulate questions about observed relationships and plan investigations of questions, ideas, problems, and issues
- conduct investigations into relationships among observable variables and use a broad range of tools and techniques to record data and information
- analyze data and apply mathematical and conceptual models to develop and assess possible solutions
- apply the skills and conventions of science in communicating information and ideas and in assessing results

---

**Science, Technology, and Society Connections (STS)**

Students will

- explain that technological problems often require multiple solutions that involve different designs, materials, and processes and that have both intended and unintended consequences
  - explain that concepts, models, and theories are often used in interpreting and explaining observations and in predicting future observations
  - explain that scientific knowledge may lead to the development of new technologies and that new technologies may lead to or facilitate scientific discovery
  - explain that the goal of technology is to provide solutions to practical problems
  - explain that scientific knowledge is subject to change as new evidence becomes apparent and as laws and theories are tested and subsequently revised, reinforced, or rejected
  - explain that scientific knowledge and theories develop through hypotheses, the collection of evidence, investigation, and the ability to provide explanations
  - explain that the goal of science is knowledge about the natural world
  - explain that the products of technology are devices, systems, and processes that meet given needs and that the appropriateness, risks, and benefits of technologies need to be assessed for each potential application from a variety of perspectives, including sustainability
-

The paper format of the *Physics 30 Diploma Examination* consists of 36 multiple-choice and 14 numerical-response questions worth 1 mark each. The digital format of the *Physics 30 Diploma Examination* consists of 50 questions worth 1 mark each of various types, including multiple-choice questions, supported by the new digital assessment platform. Fewer than half the questions require a calculation.

Questions may be either discrete or context dependent. A discrete question stands on its own without any additional directions or information. It may take the form of a question or an incomplete statement. A context-dependent, or source-based, question provides information that is separate from the question stem. A particular context may be used for more than one question.

In addition to answering multiple-choice questions, students may be asked to calculate and enter numerical values; select and/or match events, experimental variables, diagrams or descriptions modelling physics phenomena; determine and order the sequence of listed events; and rank a group of questions according to given criteria.

Questions that have multiple valid answers reflect the nature of science. They require student-generated responses that demonstrate cause-and-effect reasoning. The **potential for multiple** valid answers can be challenging to students who have been reinforced in thinking there is “**only one** right answer.”

Paper-format examples of some of these question types can be viewed in this document, as well as in released questions that can be accessed using the links provided in the Publications and Supporting Documents section as well as in the Website Links section.

Digital-format examples of some of these question types can be viewed in the Physics 30 Practice Test in the [digital assessment platform](#).

---

## Constants

Students should use constants provided on the data sheet and recorded to three significant digits rather than constants stored in calculators. This is important in order to obtain correct numerical-response answers.

# Physics 30 Diploma Examination Instructions Pages: Paper Format

Copyright © 2026, the Crown in Right of Alberta, as represented by the Minister of Education and Childcare, Alberta Education and Childcare, Provincial Assessment Sector, 6th floor, 44 Capital Boulevard, 10044 108 Street NW, Edmonton, Alberta T5J 5E6, and its licensors. All rights reserved.

Duplication of this examination in any manner or its use for purposes other than those authorized and scheduled by Alberta Education and Childcare is strictly prohibited.

The personal information collected through the Diploma Examinations Program is for the purpose of administering the program as well as support programs, policy evaluation, and measurement. This collection is authorized by section 4(c) of the *Protection of Privacy Act*. For questions about the collection of personal information, contact the Director, Diploma Programs, Provincial Assessment Sector, System Excellence, by email at [Diploma.Exams@gov.ab.ca](mailto:Diploma.Exams@gov.ab.ca) or by mail to 6th floor, 44 Capital Boulevard, 10044 108 Street NW, Edmonton, Alberta T5J 5E6.

## Physics 30 Grade 12 Diploma Examination

### Description

**Time: 3 hours.** This closed-book examination was developed to be completed in 3 hours; however, you may take up to 6 hours to complete the examination, should you need it.

This examination consists of 36 multiple-choice and 14 numerical-response questions, of equal value.

This examination contains sets of related questions. A set of questions may contain multiple-choice and/or numerical-response questions.

Tear-out data pages are included near the back of this booklet. A Periodic Table of the Elements is also provided.

### Instructions

- Turn to the last page of the examination booklet. Carefully fold and tear out the machine-scored answer sheet along the perforation.

**Note:** Additional tear-out pages at the back of this booklet may be used for your rough work. **No marks** will be given for work done on the tear-out pages.

- Use **only** an **HB** pencil for the answer sheet.
- Fill in the information on the back cover of the examination booklet and the answer sheet as directed by the presiding examiner.
- You may use **one** approved calculator: **either** a scientific calculator that does not have prohibited properties **or** a graphing calculator approved by Alberta Education and Childcare.
- You **must** have cleared your calculator of all information that is stored in the programmable or parametric memory.
- You may use a ruler and a protractor.
- Read each question carefully.
- Consider all numbers used in the examination to be the result of a measurement or an observation.
- When performing calculations, use the values of the constants provided on the tear-out pages.
- If you wish to change an answer, erase **all** traces of your first answer.
- Do **not** fold the answer sheet.
- The presiding examiner will collect your answer sheet and examination booklet and send them to Alberta Education and Childcare.
- Now read the detailed instructions for answering machine-scored questions.

## Multiple Choice

- Decide which of the choices **best** completes the statement or answers the question.
- Locate that question number on the separate answer sheet provided and fill in the circle that corresponds to your choice.

### Example

This examination is for the subject of

- A. chemistry
- B. biology
- C. physics
- D. science

Answer: C

Record C on the answer sheet:  A  B  C  D

## Numerical Response

- Record your answer on the answer sheet provided by writing it in the boxes and then filling in the corresponding circles.
- If an answer is a value between 0 and 1 (e.g., 0.25), then be sure to record the 0 before the decimal place.
- **Enter the first digit of your answer in the left-hand box. Any boxes on the right that are not needed are to remain blank.**

### Examples

#### Calculation Question and Solution

The average of the values 21.0, 25.5, and 24.5 is \_\_\_\_\_.

(Record your **three-digit** answer in the numerical-response section on the answer sheet.)

Answer: 23.7

Record 23.7 on the answer sheet →

2	3	.	7
<input type="radio"/>	<input checked="" type="radio"/>	<input type="radio"/>	<input type="radio"/>
<input type="radio"/>	<input type="radio"/>	<input type="radio"/>	<input type="radio"/>
<input type="radio"/>	<input type="radio"/>	<input type="radio"/>	<input type="radio"/>
<input checked="" type="radio"/>	<input type="radio"/>	<input type="radio"/>	<input type="radio"/>
<input type="radio"/>	<input checked="" type="radio"/>	<input type="radio"/>	<input type="radio"/>
<input type="radio"/>	<input type="radio"/>	<input type="radio"/>	<input type="radio"/>
<input type="radio"/>	<input type="radio"/>	<input type="radio"/>	<input type="radio"/>
<input type="radio"/>	<input type="radio"/>	<input type="radio"/>	<input type="radio"/>
<input type="radio"/>	<input type="radio"/>	<input type="radio"/>	<input checked="" type="radio"/>
<input type="radio"/>	<input type="radio"/>	<input type="radio"/>	<input type="radio"/>
<input type="radio"/>	<input type="radio"/>	<input type="radio"/>	<input type="radio"/>

Fill in the corresponding circles

### Sequencing Question and Solution

#### Four Subjects

- 1 Physics
- 2 Biology
- 3 Science
- 4 Chemistry

When the subjects above are arranged in alphabetical order, their order is \_\_\_\_, \_\_\_\_, \_\_\_\_, and \_\_\_\_.

(Record all **four digits** of your answer in the numerical-response section on the answer sheet.)

Answer: **2413**

Record 2413 on the answer sheet →

2	4	1	3
---	---	---	---

Fill in the corresponding circles

0	0	0	0
1	1	1	1
2	2	2	2
3	3	3	3
4	4	4	4
5	5	5	5
6	6	6	6
7	7	7	7
8	8	8	8
9	9	9	9

### Selection Question and Solution

#### Five Subjects

- 1 Art
- 2 Music
- 3 Physics
- 4 Biology
- 5 Chemistry

The science subjects in the list above are numbered \_\_\_\_, \_\_\_\_, and \_\_\_\_.

(Record all **three digits** of your answer in any order in the numerical-response section on the answer sheet.)

Answer: **345**

Record 345 on the answer sheet →

3	4	5	
---	---	---	--

Fill in the corresponding circles

0	0	0	0
1	1	1	1
2	2	2	2
3	3	3	3
4	4	4	4
5	5	5	5
6	6	6	6
7	7	7	7
8	8	8	8
9	9	9	9

**Note:** All answers containing only the three digits 3, 4, and 5, in any order, will be scored as correct.

### Scientific-notation Question and Solution

The speed of EMR in a vacuum, expressed in scientific notation, is  $a.bc \times 10^d$  m/s. The values of  $a$ ,  $b$ ,  $c$ , and  $d$  are     ,     ,     , and     .

$a$     $b$     $c$     $d$

(Record all **four digits** of your answer in the numerical-response section on the answer sheet.)

Answer:  $3.00 \times 10^8$  m/s

Record 3008 on the answer sheet

3	0	0	8
---	---	---	---

Fill in the corresponding circles

	0	1	2	3	4	5	6	7	8	9
}	0	1	2	3	4	5	6	7	8	9
	1	1	1	1	1	1	1	1	1	1
	2	2	2	2	2	2	2	2	2	2
	3	3	3	3	3	3	3	3	3	3
	4	4	4	4	4	4	4	4	4	4
	5	5	5	5	5	5	5	5	5	5
	6	6	6	6	6	6	6	6	6	6
	7	7	7	7	7	7	7	7	7	7
	8	8	8	8	8	8	8	8	8	8
	9	9	9	9	9	9	9	9	9	9

### Multiple-answer Matching Question and Solution

Continent	Country	Capital City
1 North America	4 France	7 Beijing
2 Europe	5 China	8 Ottawa
3 Asia	6 Canada	9 Paris

Using the numbers above, choose **one continent** and match it with a country in that continent and with that country's capital city. (There is more than one correct answer.)

Number: \_\_\_\_\_  
                   Continent           Country           Capital city

(Record all **three digits** of your answer in the numerical-response section on the answer sheet.)

Answer: 168 or 249 or 357

Record 168 on the answer sheet

1	6	8	
---	---	---	--

Fill in the corresponding circles

	0	1	2	3	4	5	6	7	8	9
}	0	0	0	0	0	0	0	0	0	0
	1	1	1	1	1	1	1	1	1	1
	2	2	2	2	2	2	2	2	2	2
	3	3	3	3	3	3	3	3	3	3
	4	4	4	4	4	4	4	4	4	4
	5	5	5	5	5	5	5	5	5	5
	6	6	6	6	6	6	6	6	6	6
	7	7	7	7	7	7	7	7	7	7
	8	8	8	8	8	8	8	8	8	8
	9	9	9	9	9	9	9	9	9	9

**Note:** The answers 168, 249, or 357 will be scored as correct.

## Physics 30 Diploma Examination Instructions Page: Digital Format

### Physics 30

#### Grade 12 Diploma Examination

##### Description

**Time: 3 hours.** This closed-book examination was developed to be completed in 3 hours; however, you may take an additional 3 hours, should you need it.

This examination consists of 50 questions, each worth 1 mark.

Data sheets can be viewed by clicking the Resources icon  at the right side of the screen.

A paper version of the data sheets is also permitted.

##### Instructions

- You may use **one** approved calculator: **either** a scientific calculator that does **not** have prohibited properties **or** a graphing calculator approved by Alberta Education and Childcare.
- You **must** clear your calculator of all information that is stored in the programmable or parametric memory both before and after the examination.
- You are permitted to use scrap paper for your rough work. **No marks** will be given for work done on scrap paper.
- When necessary, use the values of constants provided on the data sheets or in the information included with the question.
- If you change an answer, your examination will be automatically updated.
- To submit your **final** answers, click “Submit” on the left side of the screen.

# Physics 30 Data Pages

The [Physics 30 Diploma Examination data pages](#) are posted on the [Writing diploma exams](#) web page. They are also included on pages 23 to 25 of this document.

Students should be familiar with the data pages before writing the diploma examination.

## Periodic Table of the Elements

1 H 1.01 hydrogen	2 He 4.00 helium																														
3 Li 6.94 lithium	4 Be 9.01 beryllium	5 B 10.81 boron	6 C 12.01 carbon	7 N 14.01 nitrogen	8 O 16.00 oxygen	9 F 19.00 fluorine	10 Ne 20.18 neon																								
11 Na 22.99 sodium	12 Mg 24.31 magnesium	13 Al 26.98 aluminum	14 Si 28.09 silicon	15 P 30.97 phosphorus	16 S 32.07 sulfur	17 Cl 35.45 chlorine	18 Ar 39.95 argon																								
19 K 39.10 potassium	20 Ca 40.08 calcium	21 Sc 44.96 scandium	22 Ti 47.87 titanium	23 V 50.94 vanadium	24 Cr 52.00 chromium	25 Mn 54.94 manganese	26 Fe 55.85 iron	27 Co 58.93 cobalt	28 Ni 58.69 nickel	29 Cu 63.55 copper	30 Zn 65.39 zinc	31 Ga 69.72 gallium	32 Ge 72.64 germanium	33 As 74.92 arsenic	34 Se 78.96 selenium	35 Br 79.90 bromine	36 Kr 83.80 krypton														
37 Rb 85.47 rubidium	38 Sr 87.62 strontium	39 Y 88.91 yttrium	40 Zr 91.22 zirconium	41 Nb 92.91 niobium	42 Mo 95.94 molybdenum	43 Tc (98) technetium	44 Ru 101.07 ruthenium	45 Rh 102.91 rhodium	46 Pd 106.42 palladium	47 Ag 107.87 silver	48 Cd 112.41 cadmium	49 In 114.82 indium	50 Sn 118.71 tin	51 Sb 121.75 antimony	52 Te 127.60 tellurium	53 I 126.90 iodine	54 Xe 131.29 xenon														
55 Cs 132.91 cesium	56 Ba 137.33 barium	57-71 Lanthanide series	72 Hf 178.49 hafnium	73 Ta 180.95 tantalum	74 W 183.84 tungsten	75 Re 186.21 rhenium	76 Os 190.23 osmium	77 Ir 192.22 iridium	78 Pt 195.08 platinum	79 Au 196.97 gold	80 Hg 200.59 mercury	81 Tl 204.38 thallium	82 Pb 207.21 lead	83 Bi 208.98 bismuth	84 Po (209) polonium	85 At (210) astatine	86 Rn (222) radon														
87 Fr (223) francium	88 Ra (226) radium	89-103 Actinide series	104 Rf (261) rutherfordium	105 Db (262) dubnium	106 Sg (266) seaborgium	107 Bh (264) bohrium	108 Hs (277) hassium	109 Mt (268) meitnerium	110 Ds (271) darmstadtium	111 Rg (272) roentgenium	112 Cn (285) copernicium	113 Nh (286) nihonium	114 Fl (289) flerovium	115 Mc (289) moscovium	116 Lv (292) livermorium	117 Ts (294) tennessine	118 Og (294) oganesson														
57 La 138.91 lanthanum	58 Ce 140.12 cerium	59 Pr 140.91 praseodymium	60 Nd 144.24 neodymium	61 Pm (145) promethium	62 Sm 150.36 samarium	63 Eu 151.96 europium	64 Gd 157.25 gadolinium	65 Tb 158.93 terbium	66 Dy 162.50 dysprosium	67 Ho 164.93 holmium	68 Er 167.26 erbium	69 Tm 168.93 thulium	70 Yb 173.04 ytterbium	71 Lu 174.97 lutetium																	
89 Ac (227) actinium	90 Th 232.04 thorium	91 Pa 231.04 protactinium	92 U 238.03 uranium	93 Np (237) neptunium	94 Pu (244) plutonium	95 Am (243) americium	96 Cm (247) curium	97 Bk (247) berkelium	98 Cf (251) californium	99 Es (252) einsteinium	100 Fm (257) fermium	101 Md (258) mendelevium	102 No (259) nobelium	103 Lr (262) lawrencium																	

Key

Atomic number → 3    Li    Symbol

Atomic molar mass (g/mol) → 6.94

Name → lithium

Based on  $^{12}\text{C}$

( ) Indicates mass of the most stable isotope

## PHYSICS DATA SHEET

### Constants

Acceleration Due to Gravity Near Earth.....	$ \vec{a}_g  = 9.81 \text{ m/s}^2$
Gravitational Constant .....	$G = 6.67 \times 10^{-11} \text{ N}\cdot\text{m}^2/\text{kg}^2$
Radius of Earth .....	$r_e = 6.37 \times 10^6 \text{ m}$
Mass of Earth .....	$M_e = 5.97 \times 10^{24} \text{ kg}$
Elementary Charge.....	$e = 1.60 \times 10^{-19} \text{ C}$
Coulomb's Law Constant ..	$k = 8.99 \times 10^9 \text{ N}\cdot\text{m}^2/\text{C}^2$
Electron Volt .....	$1 \text{ eV} = 1.60 \times 10^{-19} \text{ J}$
Index of Refraction of Air.	$n = 1.00$
Speed of Light in Vacuum.	$c = 3.00 \times 10^8 \text{ m/s}$
Planck's Constant.....	$h = 6.63 \times 10^{-34} \text{ J}\cdot\text{s}$ $h = 4.14 \times 10^{-15} \text{ eV}\cdot\text{s}$
Atomic Mass Unit .....	$u = 1.66 \times 10^{-27} \text{ kg}$

### Particles

	Charge	Mass
Alpha Particle.....	$+2e$	$6.65 \times 10^{-27} \text{ kg}$
Electron .....	$-1e$	$9.11 \times 10^{-31} \text{ kg}$
Proton.....	$+1e$	$1.67 \times 10^{-27} \text{ kg}$
Neutron.....	0	$1.67 \times 10^{-27} \text{ kg}$

### First-Generation Fermions

	Charge	Mass
Electron.....	$-1e$	$\sim 0.511 \text{ MeV}/c^2$
Positron .....	$+1e$	$\sim 0.511 \text{ MeV}/c^2$
Electron neutrino, $\nu$ .....	0	$< 2.2 \text{ eV}/c^2$
Electron antineutrino, $\bar{\nu}$ .....	0	$< 2.2 \text{ eV}/c^2$
Up quark, $u$ .....	$+\frac{2}{3}e$	$\sim 2.4 \text{ MeV}/c^2$
Anti-up antiquark, $\bar{u}$ .....	$-\frac{2}{3}e$	$\sim 2.4 \text{ MeV}/c^2$
Down quark, $d$ .....	$-\frac{1}{3}e$	$\sim 4.8 \text{ MeV}/c^2$
Anti-down antiquark, $\bar{d}$ .....	$+\frac{1}{3}e$	$\sim 4.8 \text{ MeV}/c^2$

### Prefixes Used with SI Units

Prefix	Symbol	Exponential Value
atto .....	a	$10^{-18}$
femto .....	f	$10^{-15}$
pico.....	p	$10^{-12}$
nano.....	n	$10^{-9}$
micro .....	$\mu$	$10^{-6}$
milli.....	m	$10^{-3}$
centi.....	c	$10^{-2}$
deci.....	d	$10^{-1}$
deka .....	da	$10^1$
hecto .....	h	$10^2$
kilo .....	k	$10^3$
mega .....	M	$10^6$
giga.....	G	$10^9$
tera.....	T	$10^{12}$

### Physics Principles

- 0 Uniform motion ( $\vec{F}_{\text{net}} = 0$ )
- 1 Accelerated motion ( $\vec{F}_{\text{net}} \neq 0$ )
- 2 Uniform circular motion ( $\vec{F}_{\text{net}}$  is radially inward)
- 3 Work–energy theorem
- 4 Conservation of momentum
- 5 Conservation of energy
- 6 Conservation of mass–energy
- 7 Conservation of charge
- 8 Conservation of nucleons
- 9 Wave–particle duality

## EQUATIONS

### Kinematics

$$\begin{aligned}\vec{v}_{\text{ave}} &= \frac{\Delta \vec{d}}{\Delta t} & \vec{d} &= \vec{v}_i t - \frac{1}{2} \vec{a} t^2 \\ \vec{a}_{\text{ave}} &= \frac{\Delta \vec{v}}{\Delta t} & \vec{d} &= \left( \frac{\vec{v}_f + \vec{v}_i}{2} \right) t \\ \vec{d} &= \vec{v}_i t + \frac{1}{2} \vec{a} t^2 & v_f^2 &= v_i^2 + 2ad \\ |\vec{v}_c| &= \frac{2\pi r}{T} & |\vec{a}_c| &= \frac{v^2}{r} = \frac{4\pi^2 r}{T^2}\end{aligned}$$

### Dynamics

$$\begin{aligned}\vec{a} &= \frac{\vec{F}_{\text{net}}}{m} & |\vec{F}_g| &= \frac{Gm_1 m_2}{r^2} \\ |\vec{F}_f| &= \mu |\vec{F}_N| & |\vec{g}| &= \frac{Gm}{r^2} \\ \vec{F}_s &= -k\vec{x} & \vec{g} &= \frac{\vec{F}_g}{m}\end{aligned}$$

### Momentum and Energy

$$\begin{aligned}\vec{p} &= m\vec{v} & E_k &= \frac{1}{2}mv^2 \\ \vec{F}\Delta t &= m\Delta\vec{v} & E_p &= mgh \\ W &= |\vec{F}||\vec{d}|\cos\theta & E_p &= \frac{1}{2}kx^2 \\ W &= \Delta E \\ P &= \frac{W}{t}\end{aligned}$$

### Waves

$$\begin{aligned}T &= 2\pi\sqrt{\frac{m}{k}} & m &= \frac{h_i}{h_o} = \frac{-d_i}{d_o} \\ T &= 2\pi\sqrt{\frac{l}{g}} & \frac{1}{f} &= \frac{1}{d_o} + \frac{1}{d_i} \\ T &= \frac{1}{f} & \frac{n_2}{n_1} &= \frac{\sin\theta_1}{\sin\theta_2} \\ v &= f\lambda & \frac{n_2}{n_1} &= \frac{v_1}{v_2} = \frac{\lambda_1}{\lambda_2} \\ f &= \left( \frac{v}{v \pm v_s} \right) f_s & \lambda &= \frac{d \sin\theta}{n} \\ \lambda &= \frac{xd}{nl}\end{aligned}$$

### Electricity and Magnetism

$$\begin{aligned}|\vec{F}_e| &= \frac{kq_1 q_2}{r^2} & \Delta V &= \frac{\Delta E}{q} \\ |\vec{E}| &= \frac{kq}{r^2} & I &= \frac{q}{t} \\ \vec{E} &= \frac{\vec{F}_e}{q} & |\vec{F}_m| &= I l_{\perp} |\vec{B}| \\ |\vec{F}| &= \frac{\Delta V}{\Delta d} & |\vec{F}_m| &= qv_{\perp} |\vec{B}|\end{aligned}$$

### Atomic Physics

$$\begin{aligned}W &= hf_0 & E &= hf = \frac{hc}{\lambda} \\ E_{k,\text{max}} &= q_e V_{\text{stop}} & N &= N_0 \left( \frac{1}{2} \right)^n\end{aligned}$$

### Quantum Mechanics and Nuclear Physics

$$\begin{aligned}\Delta E &= \Delta mc^2 & E &= pc \\ p &= \frac{h}{\lambda} & \Delta\lambda &= \frac{h}{mc}(1 - \cos\theta)\end{aligned}$$

### Trigonometry and Geometry

**Line**

$$m = \frac{\Delta y}{\Delta x}$$

$$y = mx + b$$

**Area**

Rectangle =  $lw$

Triangle =  $\frac{1}{2}ab$

Circle =  $\pi r^2$

**Circumference**

Circle =  $2\pi r$

$\sin\theta = \frac{\text{opposite}}{\text{hypotenuse}}$

$\cos\theta = \frac{\text{adjacent}}{\text{hypotenuse}}$

$\tan\theta = \frac{\text{opposite}}{\text{adjacent}}$

$c^2 = a^2 + b^2$

$\frac{a}{\sin A} = \frac{b}{\sin B} = \frac{c}{\sin C}$

$c^2 = a^2 + b^2 - 2ab \cos C$

---

## Using Calculators

The *Physics 30 Diploma Examination* requires the use of a calculator that does not have prohibited properties or a graphing calculator approved by Alberta Education and Childcare. The calculator rules, list of prohibited properties, criteria, and keystrokes for clearing approved graphing calculators are found in *2025–26 Calculator Information and Rules for Mathematics and Science Diploma Exams* on the [Writing diploma exams](#) web page.

Teachers should be aware of the capabilities of approved graphing calculators that are available when the calculator is not configured for exam purposes, as these capabilities may impact classroom instruction and assessment. These capabilities may also be applicable to other high school math and science courses.

---

## Assessment of Skills and STS Connections

*Physics 30 Diploma Examination* items are designed to measure students' understanding of physics concepts mandated by the [Physics 20–30 Program of Studies, 2007 \(Updated 2014\)](#). Some items also measure students' understanding and use of skills associated with scientific inquiry, and some items have been designed to measure students' understanding of the connections among STS. As a result, many items measure how well students can apply the skills and knowledge they have acquired in science to everyday life.

## Illustrative Graphing Skills

The following set of items illustrates how graphical analysis can be assessed on the *Physics 30 Diploma Examination*.

Use the following information to answer question 11 and numerical-response question 9.

Students performed an experiment using two low-friction laboratory carts. A piece of timer tape was attached to Cart I and fed through a spark timer apparatus. The timer made a mark on the tape each 0.10 s. Cart I was pushed toward Cart II, which was initially at rest. The carts collided, the piece of clay was deformed and held the carts together as they continued to move. The mass of Cart I is 1.54 kg.

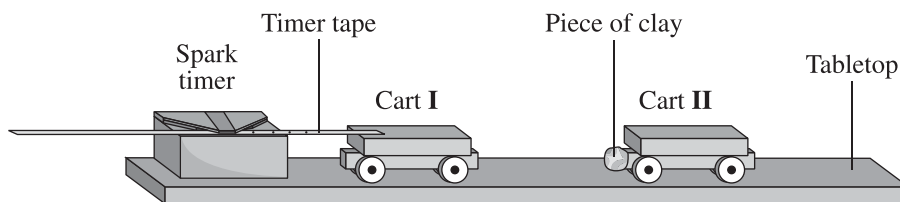

The students repeated the above procedure, manipulating the initial speed of Cart I.

The graph of their observations is given below.

**Speed of Carts I and II (After the Collision) as a Function of the Speed of Cart I (Before the Collision)**

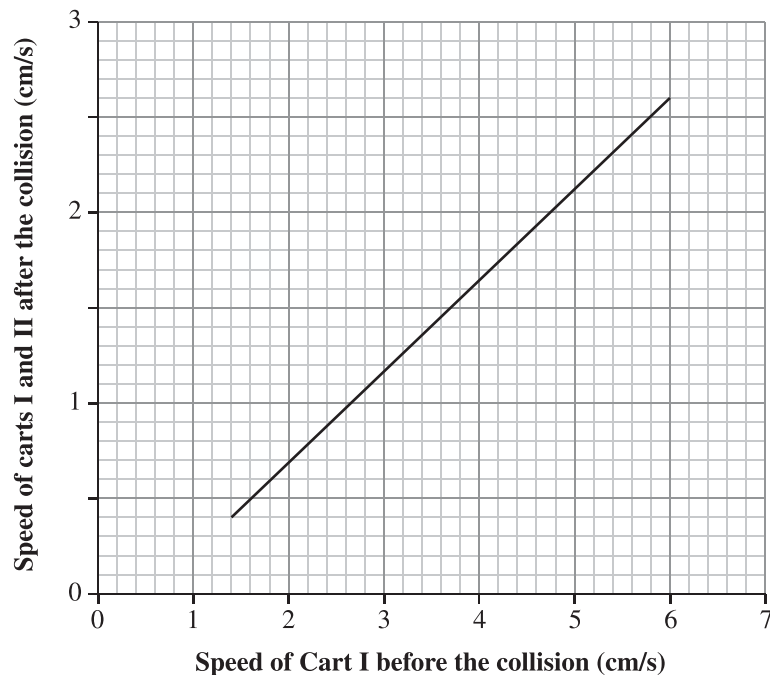

11. The collision of the two carts is classified as   *i*   because   *ii*  .

The statement above is completed by the information in row

Row	<i>i</i>	<i>ii</i>
A.	elastic	momentum is conserved
B.	elastic	kinetic energy is conserved
C.	inelastic	momentum is not conserved
D.	inelastic	kinetic energy is not conserved

The answer is D.

### Numerical Response

9. Based on the slope of the line of best fit, the **combined** mass of the two carts is \_\_\_\_\_ kg.

(Record your **three-digit answer** in the numerical-response section on the answer sheet.)

Answers: 3.20, 3.21, 3.22, 3.23, 3.24, 3.25, 3.26

## Illustrative Numerical-response Items Assessing Mandated Skills

This section illustrates how student-made measurements can be incorporated into machine-scored items on the *Physics 30 Diploma Examination*. This item assesses outcomes B2.8k, B2.2s, and B2.3s.

30 B2.8k, *Students will describe, quantitatively, the motion of an electric charge in a uniform electric field*; B2.2s, *Students will conduct investigations among observable variables and use a broad range of tools and techniques to gather and record data and information*; B2.3s, *Students will analyze data and apply mathematical and conceptual models to develop and assess possible solutions*.

*Use the following information to answer numerical-response questions 1 and 2.*

A beam of electrons is incident on a region containing a uniform electric field as shown below. The electrons in the beam each have a speed of  $4.5 \times 10^5$  m/s. While in the electric field the electrons accelerate toward the top plate.

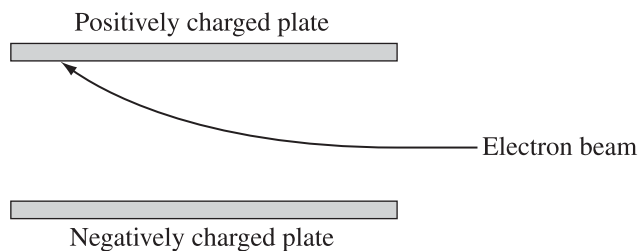

**Note:** You will want to make your measurements on this diagram.

## Numerical Response

1. Based on your measurements, the strength of the uniform electric field in the region is \_\_\_\_\_ N/C.

(Record the **two digits** of your answer in the numerical-response section on the answer sheet.)

Answer: 14 or 15 or 13

## Numerical Response

2. Two physics principles must be used to determine the strength of the uniform electric field. Using the numbers on the tear-out data sheet, match the physics principles with the order in which they are used. (There is more than one correct answer.)

**Number:** \_\_\_\_\_ and \_\_\_\_\_  
**Physics principle:** Used first                      Used second

(Record **both digits** of your answer in the numerical-response section on the answer sheet.)

Answer: 0 and 1, in any order

**Note:** Although conservation of energy (5) or the work–energy theorem (3) could be used, they are not the most-direct method as the algebra eventually requires the use of a force in the vertical direction.

This item illustrates the design-an-experiment skill mandated in program of studies outcome B3.1s.

B3.1s, *Students will* formulate questions about observed relationships and plan investigations of questions, ideas, problems and issues • design an experiment to demonstrate the effect of a uniform magnetic field on a current-carrying conductor.

*Use the following information to answer numerical-response question 3.*

A group of students sets up the apparatus shown below.

### Apparatus

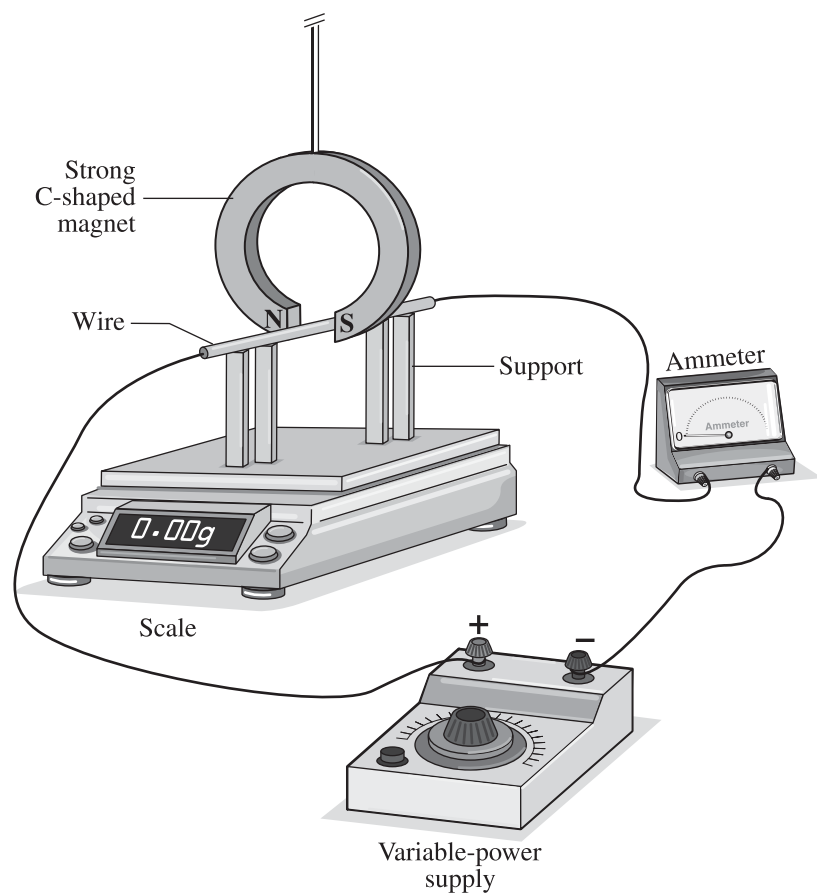

### Research Questions

- 1 Does the length of the wire in the magnetic field affect the magnetic force?
- 2 Does the magnitude of the current in the wire affect the magnetic force?
- 3 Does the strength of the magnetic field produced by the C-shaped magnet affect the magnetic force?
- 4 Does the direction of the electron flow affect the magnetic force?
- 5 Does the orientation of the wire relative to the external magnetic field affect the magnetic force?

### Variables

- 6 Force on wire
- 7 Length of wire
- 8 Strength of the C-shaped magnet
- 9 Current in wire

### Numerical Response

3. Using the numbers above, choose **one research question** that could be investigated using the apparatus and match three of the variables to their respective roles in the investigation of that research question as given below. (There is more than one correct answer.)

Number:

\_\_\_\_\_ **Research question**

\_\_\_\_\_ **Manipulated variable**

\_\_\_\_\_ **Responding variable**

\_\_\_\_\_ **One of the variables that must be controlled**

(Record all **four digits** of your answer in the numerical-response section on the answer sheet.)

Answer: 1768, 1769, 2967, 2968, 4967, or 4968





This item illustrates how students can design an investigation by selecting apparatus and then by analyzing the results from their design. This is mandated in program of studies outcomes C1.1s, C1.2s, and C1.3s.

C1.1s, *Students will formulate questions about observed relationships and plan investigations of questions, ideas, problems and issues;* C1.2s, *Students will conduct an investigation to determine the focal length of a thin lens and of a curved mirror;* and C1.3s, *Students will use ray diagrams to describe an image formed by thin lenses and curved mirrors.*

*Use the following information to answer numerical-response question 4.*

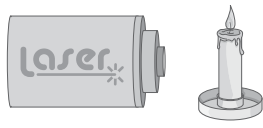
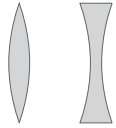
Students use three of the optical apparatus illustrated below to produce a **focused, real** image in a darkened room. One of the apparatus has a focal length of 10.0 cm.

### Optical Apparatus

Sources	Lenses	Mirrors	Diffraction grating	Double-slit apparatus	Screen
					
<b>0</b>	<b>1</b>	<b>2</b> <b>3</b>	<b>4</b> <b>5</b> <b>6</b>	<b>7</b>	<b>8</b> <b>9</b>

The students place one apparatus at each labelled location on an optics bench, as shown below. The optics bench is scaled in millimetres and labelled in centimetres.

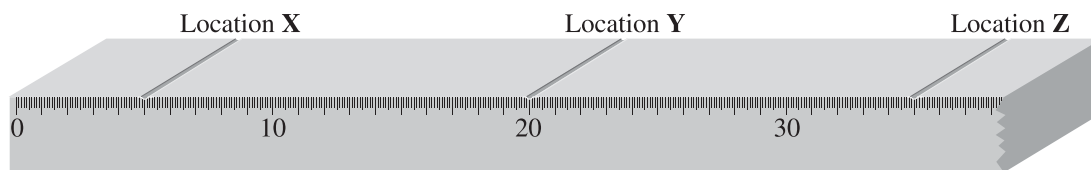

**Note:** The diagrams are **not** drawn to scale.

## Numerical Response

4. The apparatus placed at location

**X** is numbered \_\_\_\_\_ (Record in the **first** column)

**Y** is numbered \_\_\_\_\_ (Record in the **second** column)

**Z** is numbered \_\_\_\_\_ (Record in the **third** column)

(Record your answer in the numerical-response section on the answer sheet.)

Answers: 194, 094, 491, or 490

### Commentary

This section of the program of studies, C1, is intended to be very hands-on. In a standardized assessment context, we need to illustrate the optics experiences that students should have had. To that end, we chose the simple device of a metre stick on its side. Apparatus can be positioned on the metre stick, beside the metre stick, and at one edge of the metre stick. Based on where the apparatus are positioned, students can make predictions or actual measurements. The list of apparatus matches some of the mandated optics experiences.

This question is not at recall level because, since the object is more than a focal length away from the mirror, the screen (where the image is observed) is between the mirror and the object. When the students are faced with this conundrum in the lab, they have to explore how putting the object and the image just a bit off the axis allows the geometry to work and a real image to form.

This type of question has many possible applications for assessing experimental design and measurement skills.

This item illustrates how students can demonstrate the performing and recording skills mandated by program of studies outcome C1.2s.

C1.2s, *Students will* conduct investigations into relationships among observable variables and use a broad range of tools and techniques to gather and record data and information • perform an experiment to determine the index of refraction of several different substances.

*Use the following information to answer numerical-response question 5.*

A ray of light travelling from water into an unknown medium is shown below.

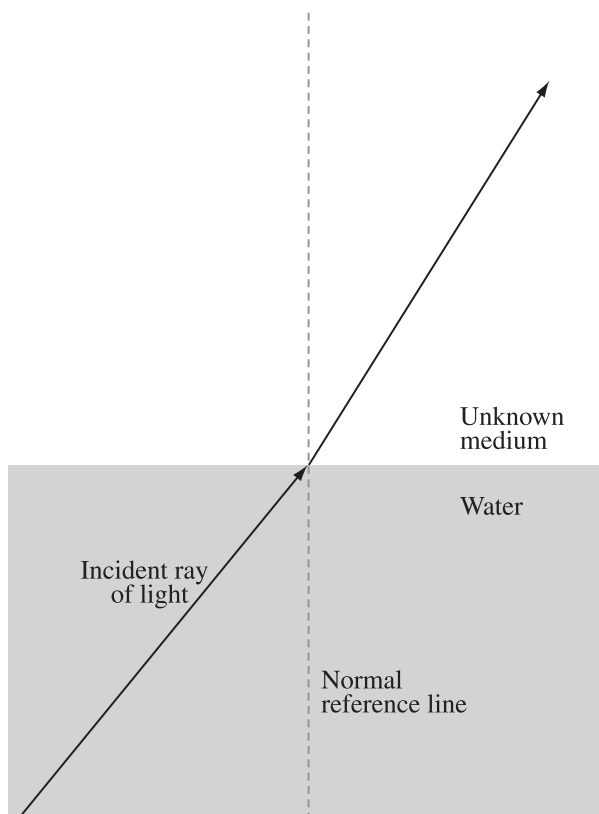

**Note:** You will need to make measurements using a ruler or a protractor.

## Numerical Response

5. If the index of refraction of the water is 1.33, then the index of refraction of the second medium is \_\_\_\_\_.

(Record your **three-digit answer** in the numerical-response section on the answer sheet.)

Answer: Any value between 1.54 and 1.69

This item allows students to explore the technology of a velocity selector tuned so that the path of positively charged ions is undeflected. In order to be able to do the quantitative analysis correctly, the ability to build a free-body diagram is a prerequisite.

B3.6k, *Students will explain, quantitatively, how uniform magnetic and electric fields affect a moving electric charge, using the relationships among charge, motion, field direction and strength, when motion and field directions are mutually perpendicular*; B2.6k, *Students will explain, quantitatively, electric fields in terms of intensity (strength) and direction, relative to the source of the field and to the effect on an electric charge*; B3.3s, *Students will analyze data and apply mathematical and conceptual models to develop and assess possible solutions* • analyze, quantitatively, the motion of an electric charge following a straight path in uniform and mutually perpendicular electric and magnetic fields, using Newton's second law and vector addition; B2.3s, *Students will analyze data and apply mathematical and conceptual models to develop and assess possible solutions* • use free-body diagrams to describe the forces acting on a charge in an electric field.

Use the following information to answer numerical-response question 6.

A positively charged ion travels through a region that contains perpendicular electric and magnetic fields. The ion passes through the region undeflected at a constant speed.

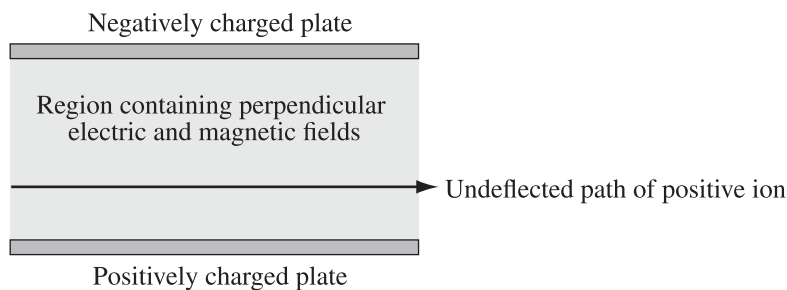

**Directions**



## Numerical Response

6. Match the numbers on the directions given above with the descriptions given below.

<b>Direction:</b>	_____	_____	_____	_____
<b>Description:</b>	<b>Direction of the electric force on the ion</b>	<b>Direction of the electric field in the region</b>	<b>Direction of the magnetic force on the ion</b>	<b>Direction of the magnetic field in the region</b>

(Record all **four digits** of your answer in the response area at the bottom of the screen.)

Answer: 5560

### Commentary

In order for students to determine the correct answer, they likely used the following process.

The direction of the electric force is toward the negatively charged plate (opposites attract). The arrow that is in that direction is numbered 5.

The direction of the electric field is defined as the direction of the force on a positive test charge, which is the same direction as the force. This direction is numbered 5.

The next blank requires the students to apply several ideas: undeflected motion means net force is zero, and there are exactly two significant forces acting on the positively charged particle. So the magnetic force must be in the opposite direction to that of the electric force, and this direction is numbered 6.

Finally, the students use a hand rule to determine the relative orientations of the velocity, force, and magnetic field. As a result, students should see that the magnetic field is perpendicular to the velocity and force and directed out of the plane of the diagram. The direction that shows this is the point of the arrow, numbered 0.

### Analysis of field-test data

Just over 37% of the students who answered this question were able to get the directions of the electric force and electric field correct. Another 1% got the direction wrong and indicated that both directions were the same. Just over 37% of the students who answered this question provided directions for the first and third blanks that were opposite to each other. Finally, just over 58% of the students who answered this question provided a direction of the magnetic field that was perpendicular to the plane of the diagram.

## Illustrative Items from Field Testing or Diploma Examinations Showing Word Usage and Exploring Misconceptions

These items have been chosen to illustrate some students' strongly held misconceptions and word usage on the diploma examination.

The first item explores the misconceptions that some students hold regarding Newton's third law.

*Use the following information to answer question 1.*

Two carts, travelling at the same initial speed, move toward each other on a table, as shown below. Cart I has a total mass of 500 g and Cart II has a total mass of 250 g.

### Side View of Colliding Carts

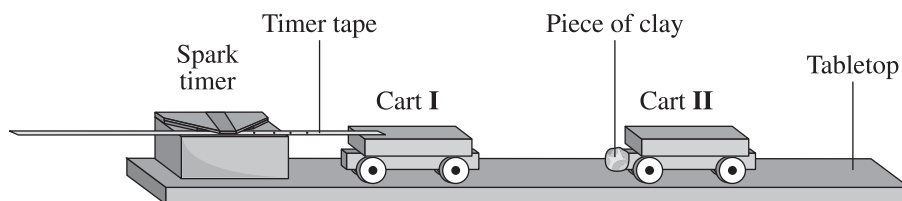

The carts collide. After contact, the carts remain separate from each other and move independently.

1. Which of the following vector diagrams, drawn to scale, shows the magnitude and direction of the impulse experienced by each cart during contact?

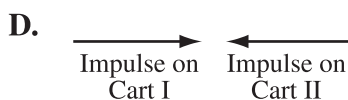
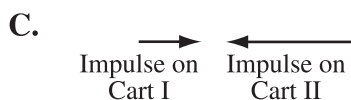
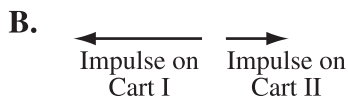
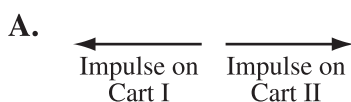

The answer is A.

### Commentary

This question explores the application of Newton's third law in the student-familiar context of a collision. The majority of the students who answered this question were divided between choices B and C. This reflects a strongly held misconception of the relationship between force and acceleration.

This item is included because student performance on the field-test item suggests they struggle with this program outcome.

B1.3k, *Students will compare the methods of transferring charge (conduction and induction); and B1.4k, Students will explain, qualitatively, the distribution of charge on the surfaces of conductors and insulators.*

*Use the following information to answer question 2.*

A negatively charged rod is brought into contact with an initially neutral sphere supported by an insulated stand. The rod is removed and the resulting net charge distribution on the sphere is illustrated below.

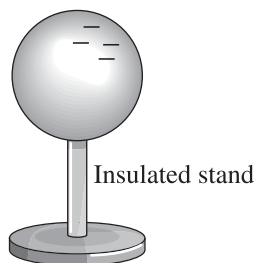

2. *The sphere has been charged by the process of \_\_\_ **i** \_\_\_, and the material that the sphere is made of is classified as \_\_\_ **ii** \_\_\_.*

The statement above is completed by the information in row

Row	<i>i</i>	<i>ii</i>
A.	induction	a conductor
B.	induction	an insulator
C.	conduction	a conductor
D.	conduction	an insulator

The answer is D.

### Commentary

In general, students were unsuccessful in answering this question. The diagram illustrates that the nature of the excess charge is the same as that of the charging rod, which should allow the students to recognize that the method of charging is conduction. Since the excess charge remains localized on the surface of the sphere, students should recognize this as a characteristic of an electrical insulator.

This group of four items illustrates how outcome B3.9k can be assessed.

*Use the following information to answer question 3.*

A copper sheet is pulled through a magnetic field, as shown below. Each of the edges is numbered.

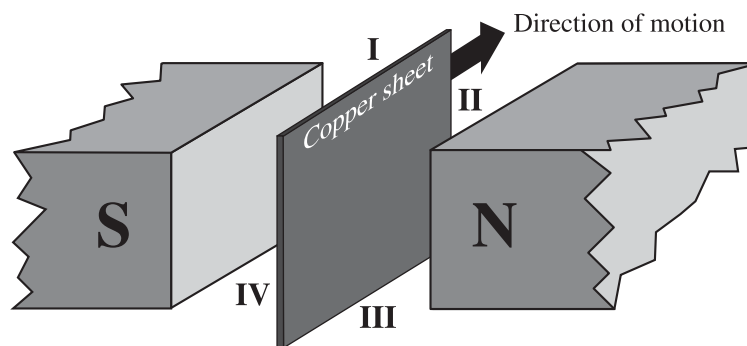

3. As a result of the motion of the copper sheet in the magnetic field, the edge of the copper sheet that becomes relatively negatively charged is numbered

- A. I
- B. II
- C. III
- D. IV

The answer is C.

Use the following information to answer question 4.

A metal wire is located in the region between two opposite magnetic poles, as shown in the diagram below. Six numbered directions are also indicated.

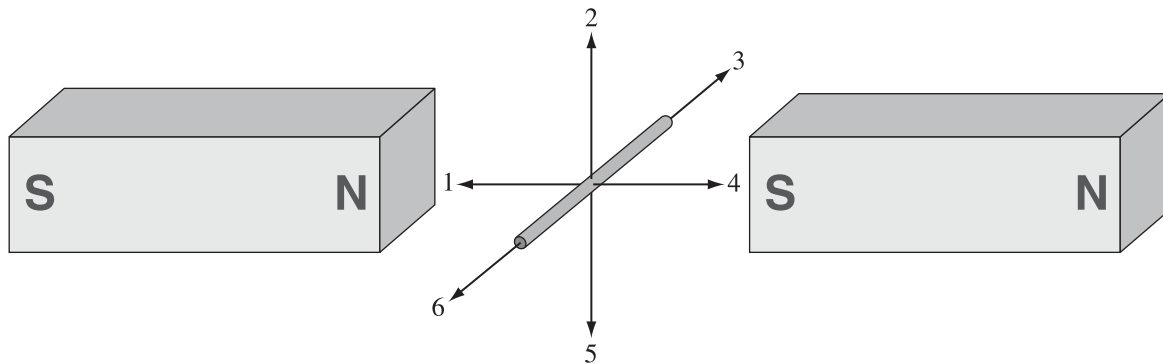

4. To induce a flow of electrons in the direction of 3, the wire must be moved in the direction of
- A. 1
  - B. 2
  - C. 4
  - D. 5

The answer is D.

Use the following information to answer question 5.

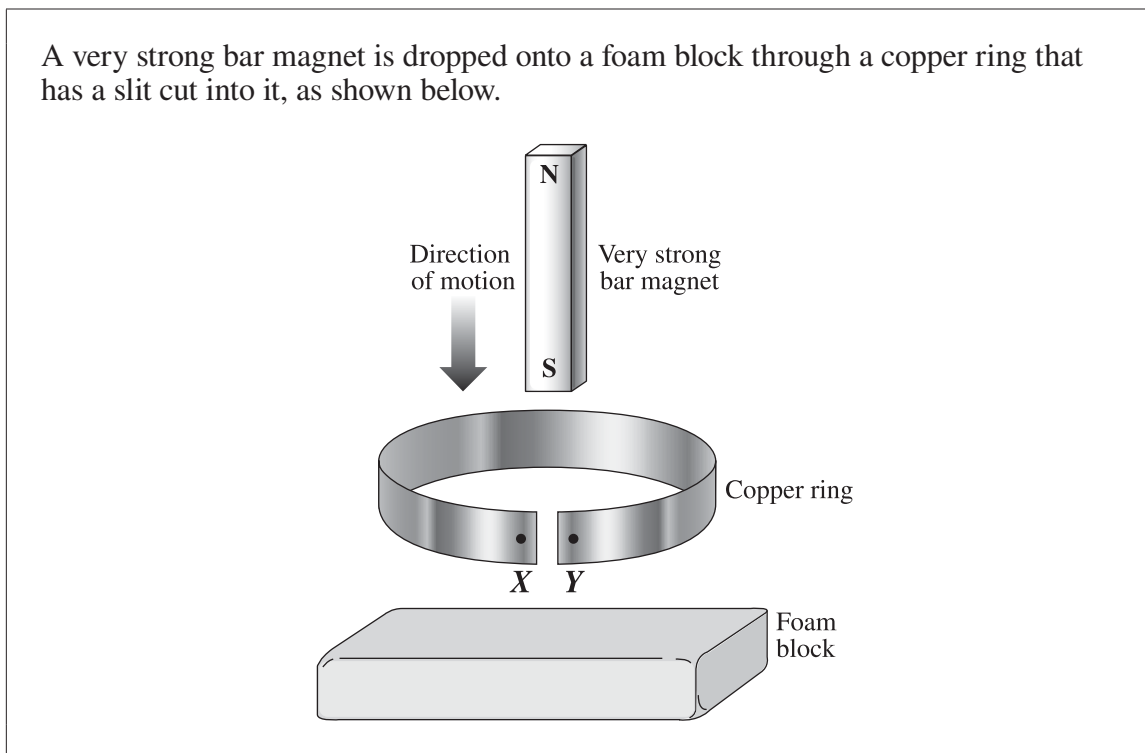

5. When the south pole of the magnet moves into the ring from above, the direction the electrons inside the copper ring will move is from   *i*  . Compared to X, the nature of the charge on Y will be relatively   *ii*  .

The statements above are completed by the information in row

Row	<i>i</i>	<i>ii</i>
A.	X to Y	negative
B.	X to Y	positive
C.	Y to X	negative
D.	Y to X	positive

The answer is D.

Use the following information to answer question 6.

A positively charged sphere is suspended on the end of an insulated string in the region between two vertical, metal, parallel plates that are connected to a coil of wire. A magnet is suddenly thrust into the coil of wire, as illustrated below.

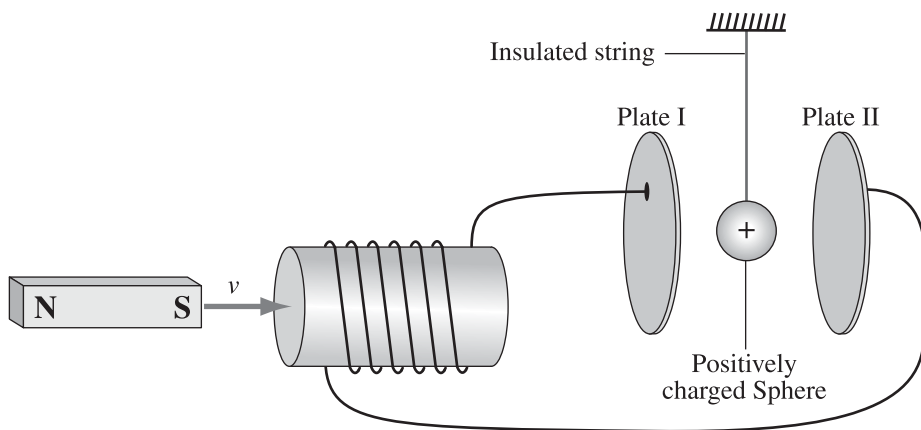

6. When the magnet is moved as illustrated above, then the direction of the motion of the positively charged sphere is
- A. into the page
  - B. toward Plate I
  - C. toward Plate II
  - D. out of the page

The answer is C.

This group of two items illustrates the use of *convex* and/or *concave* for a mirror and *diverging* and/or *converging* for a lens.

These words are chosen to make the items completely unambiguous. A convex mirror can only reflect the light off one face and the ray diagram is clear. However, a convex–convex lens can be either diverging or converging depending on the relative positions of the surfaces. So that students know exactly what is happening, we describe the effect of the lens on the light.

*Use the following information to answer question 7.*

When a girl who is 122 cm tall stands 40 cm in front of a particular mirror, her virtual image in the mirror is upright and 54 cm tall.

7. The mirror is   *i*  , and the girl's image is located   *ii*   away from the mirror.

The statement above is completed by the information in row

Row	<i>i</i>	<i>ii</i>
A.	convex	18 cm
B.	convex	90 cm
C.	concave	18 cm
D.	concave	90 cm

The answer is A.

*Use the following information to answer question 8.*

In an investigation, a group of students measures an object to be 10.0 cm tall. They place the object 3.2 cm in front of a thin lens. The students are unable to locate a real, focused image. They draw a ray diagram and notice that the focused virtual image forms on the same side of the lens as the object and is 1.3 times larger than the object.

8. The type of lens and its calculated focal length are, respectively,
- A. diverging, and 1.8 cm
  - B. diverging, and 14 cm
  - C. converging, and 1.8 cm
  - D. converging, and 14 cm

The answer is D.

This two-item set illustrates the assessment of Unit D outcomes D3.5k, D3.3s, and D3.6k. The context also shows that a fusion reaction equation can include more than one product.

D3.5k, *Students will compare and contrast the characteristics of fission and fusion reactions*; D3.3s, *Students will compare the energy released in a nuclear reaction to the energy released in a chemical reaction, on the basis of energy per unit mass of reactants*; and D3.6k, *Students will relate, qualitatively and quantitatively, the mass defect of the nucleus to the energy released in nuclear reactions, using Einstein's concept of mass–energy equivalence.*

Use the following information to answer question 9 and numerical-response question 7.

**Nuclear Reactions**

**Reaction I:**  ${}^2_1\text{H} + {}^3_1\text{H} \rightarrow {}^4_2\text{He} + {}^1_0\text{n}$

**Reaction II:**  ${}^{235}_{92}\text{U} + {}^1_0\text{n} \rightarrow {}^{141}_{56}\text{Ba} + {}^{92}_{36}\text{Kr} + 3{}^1_0\text{n}$

Reaction II is currently used in nuclear reactors in Canada. When 1.00 kg of uranium fuel reacts,  $6.11 \times 10^{13}$  J of energy is released.

9. Which of the following rows identifies the fission reaction and compares the energy released in the two reactions per kilogram of reactants?

Row	Fission	Energy per Kilogram
A.	Reaction I	Reaction I releases more than Reaction II
B.	Reaction I	Reaction I releases less than Reaction II
C.	Reaction II	Reaction I releases more than Reaction II
D.	Reaction II	Reaction I releases less than Reaction II

The answer is C.

### Numerical Response

7. The mass equivalent of the energy released by the burning of uranium fuel in a Canadian nuclear reactor, expressed in scientific notation, is  $a.bc \times 10^{-d}$  kg. The values of  $a$ ,  $b$ ,  $c$ , and  $d$  are \_\_\_\_\_, \_\_\_\_\_, \_\_\_\_\_, and \_\_\_\_\_.
- $a$        $b$        $c$        $d$

(Record all **four digits** of your answer in the numerical-response section on the answer sheet.)

The answer is 6794.

This item illustrates the difference between *use* and *derive* in the context of the de Broglie equation. By providing the equation and naming the variables, students use  $p = mv$  from A1.1k to solve the problem. Without the equation in the context box, this question is beyond the expectations of the program of studies.

*Use the following information to answer question 10.*

Solar wind is hot plasma ejected from the surface of the Sun. The plasma consists, in part, of electrons. de Broglie hypothesized that a moving particle has an associated wavelength that relates to its momentum, given by the formula below.

$$\lambda = \frac{h}{p}$$

- 10.** The associated wavelength of one solar-wind electron that has a measured speed of  $4.0 \times 10^5$  m/s is
- A.**  $9.9 \times 10^{-13}$  m
  - B.**  $1.8 \times 10^{-9}$  m
  - C.**  $6.2 \times 10^6$  m
  - D.**  $1.1 \times 10^{10}$  m

The answer is B.

## Trends in Student Performance

The following points are in response to comments from students and teachers on field tests, comments from teachers on the perusal copies of the diploma examinations, and comments made by teachers at professional development opportunities. These points also reflect areas of student strengths (i.e., items many students get correct) and areas for improvement (i.e., items many students do not get correct). Each point is linked to program of studies outcome(s).

### Comments relating to general skills outcomes

(.1s) When students are asked about experimental design, they have difficulty identifying which variable(s) to control. However, students are very successful at identifying what was manipulated and what responded.

(.2s) Students have difficulty in deciding what a valid measurement is and what affects the quality of the data that are based on measurements. This includes measuring inside-to-inside distances on a dot-timer track or between antinodes in an interference pattern. Students also measure angles to the nearest  $5^\circ$  rather than making the best estimate based on the scale on the protractor. They will choose to make an observation of a smaller value rather than a larger value, which indicates that they are not attempting to minimize the inherent relative error in the measurement.

Students may be asked to make measurements on diagrams using a ruler or protractor. Students may be prompted in the context box or stem of the item that measurements are required. As a rule, the diagrams on the *Physics 30 Diploma Examination* are drawn to scale; and when this is not the case, a note will be provided stating that the diagram is not drawn to scale.

(.3s) Students are very good at calculating the slope of a line but experience significant difficulty in relating the slope,  $m$ , from  $y = mx + b$ , to the physics that describes the situation. This ability to map one model onto another is a measure of non-algorithmic thinking that is necessary to achieve the standard of excellence in Physics 30. This analysis should be modelled for Physics 20 students, but they will likely not be able to complete such an analysis independently.

Students experience increased difficulty calculating the slope of a line when the values on the horizontal and/or the vertical scale of a graph do not start at zero. Students should be encouraged to read the scale increments on the axes of a graph carefully.

Students are very successful at identifying the directions of forces acting on masses. Students are good at identifying the directions of forces acting on stationary charges as long as Newton's third law does not need to be applied. Students have limited success in applying hand rules to describe the relationship between direction of motion, type of charge, and direction of magnetic field. This weakness has increased each year that a machine-scored-only examination has been in place.

(.4s) Students experience significant challenges in evaluating the quality of results. This is consistent with their measurement practices.

### Comments relating to specific knowledge outcomes

On items that assess C1.8k, students have difficulty in using diffraction and interference correctly. The dispersion of the energy as a wave moves past a barrier is diffraction. When waves overlap and their energy temporarily superimposes, the observation of the net energy shows interference.

Students are able to analyze balanced forces in the context of B2.10k, a Millikan situation, or B3.6k, a velocity selector. They tend to struggle when the magnetic force on a current-carrying conductor is balanced by the gravitational force.

Students are able to analyze a single unbalanced force causing linear acceleration (B1.6k, B1.3s, and B2.8k, B2.3s) or circular motion (B3.5k, B3.3s). Students have significant difficulty analyzing a situation in which the forces are unbalanced but still parallel/anti-parallel (B2.10k, B2.3s, and B3.6k, B3.3s).

Students should know the relationships among the direction of a net unbalanced force, the initial direction of particle motion, and the resulting path shape. The description of a path shape as linear, parabolic, or circular should immediately convey the relevant physics applications. The converse is also true: from a description of the physics, students should be able to identify the expected path shape.

Students experience significant difficulty with B3.2s, use of hand rules. The misconception of describing magnetic interactions using electrostatic principles or vice versa is often a more popular choice than the correct answer on multiple-choice items.

The term *EMR* will be used in place of electromagnetic radiation when appropriate. This relates to C1. The term *LED* will be used in place of light emitting diode when appropriate. LEDs have become more commonly used in contexts describing an EMR source.

Outcomes D3.2k and D3.4k require students to bring different skills and cognition to the process of writing and balancing nuclear reactions. Students are very successful at D3.2k and are able to correctly match the particle/antiparticle pairs. Students are also very successful at balancing nuclear-decay reactions. They experience significant difficulty in meeting the expectation of D3.4k, apply conservation of charge and conservation of mass number. This suggests that students may be doing arithmetic on the top and bottom numbers rather than understanding the importance of what the numbers represent. D3.4k can also be assessed by asking the students to convert a description of a reaction into a balanced decay equation.

Outcome D3.5k is related to but goes beyond D3.3s. Students are generally successful identifying that fusion reactions release more energy per unit mass than fission reactions. They experience significant difficulty when asked to identify which type of nuclear reaction releases more energy per reaction or more energy per nucleon. Students should know that, when compared to fusion reactions, spontaneous fission reactions release less energy per unit of mass and less energy per nucleon, but more energy per reaction. **Note:** Some resources common to Alberta classrooms contain incorrect information relating to this outcome.

### Comments on conservation of energy

A1.5k – Students are very successful at classifying collision interactions as elastic or inelastic.

B2.9k – Students are successful at applying conservation of energy in a uniform electric field if the starting or ending speed is zero. Students are less successful if the charged particle has some kinetic energy before or after experiencing a force or moving through a potential difference. Students are much less successful if the force or potential difference acts to reduce the kinetic energy of the charged particle.

C2 – Students are very successful at using energy principles in calculations dealing with the photoelectric effect. Students are less successful at using conservation of energy principles in analyzing a Compton scattering event. This is an interesting observation, as students are very successful at classifying collisions based on changes to the energy of a system. This suggests students may be using algorithm-based methods in Unit A rather than physics principles in response to a particular context.

D2.5k – Students are successful at calculations relating to energy-level transitions when an energy level diagram is provided. They are much more successful at calculations relating to situations in which photon energy is released. Students are less successful when they need to combine the idea of an elastic collision (an incoming electron causing the excitation) and determining the possible excited state of the target atom. Students are also less successful at relating energy levels to ionization energy and to the work function of a surface. Again, this suggests that students may be applying particular algorithms rather than general physics principles when analyzing situations.

The emission of gamma photons by an excited nucleus as part of radioactive decay can be modelled as a change in energy states analogous to the emission of a photon by an excited atom or molecule. Students who have a superficial understanding of conservation of energy struggle with this application, while students who have a big-picture foundation experience success.

D3.6k – Students are very successful at using the equation  $\Delta E = \Delta mc^2$  when they are given the energy in units of either J or eV or mass in units of kg. They are less successful when they need to apply the equation to a table of masses associated with a particular nuclear reaction or when describing an annihilation reaction.

## Physics principles

The linking of two of the 10 physics principles given on the data sheet to the solution to a problem continues to be a challenge for many students. This is most directly assessed on the two-question scenario that appears at the end of the diploma examination: numerical-response question 13 asks the students to calculate something, and numerical-response question 14 asks the students to identify the two physics principles they used.

In general, for this type of question, there are some situations in which one principle is subsumed by another (e.g., circular motion and accelerated motion). There are some situations in which two principles are equivalent (e.g., work–energy theorem and conservation of energy), but this is not always true. This type of question is not likely to reward memorization. Students should be recording the order in which they used the principles. The examination key accepts either order.

For more examples of the assessment of physics principles using questions like numerical-response question 13 and numerical-response question 14, see the *Physics 30 Archived Information Bulletin* at the [Writing diploma exams](#) web page or the practice questions on [Quest A+](#).

For an example of the assessment of physics principles using questions like numerical-response question 13 and numerical-response question 14 in the digital assessment platform, see questions 21 and 22 in the Physics 30 Practice Test in the [digital assessment platform](#). For the 2025–2026 school year, question 50 of the digital format of the *Physics 30 Diploma Examination* will use a format style similar to question 22 in the Physics 30 Practice Test in the [digital assessment platform](#).

## Clarifications

This section describes the expectations mandated in the [Physics 20–30 Program of Studies 2007 \(updated 2014\)](#) as assessed on the *Physics 30 Diploma Examination*. Only selected portions of the program of studies are addressed here. The selection is based on comments from teachers or student performance on field tests and diploma examinations.

For a description of what is expected at the classroom or student level, please refer to *Student-Based Performance Standards* posted on the [Writing diploma exams](#) web page.

### Expectations that span all the general outcomes

#### Specific outcomes for skills

- .1s: *Students will formulate questions about observed relationships and plan investigations of questions, ideas, problems and issues*
- design an experiment and identify and control major variables

A controlled variable is one that, if not controlled, would reduce the confidence of the conclusions based on the observations. The manipulated variable is the one that, in a fair test, is changed by the researcher. The responding variable is the only one that responds directly to the changes in the manipulated variable. The *Physics 30 Diploma Examination* will not use the terms *dependent* and *independent variables*.

- .2s: *Students will conduct investigations into relationships among observable variables and use a broad range of tools and techniques to gather and record data and information*

Students should know how to use a ruler to measure length or use a protractor to measure angles. They should know that they must estimate the last digit since this is the foundation of why measurements have significant digits and that the estimate produces error. Students should also know that the reduction of the significance of this error is increased if the measurement is as large as possible for the equipment being used. For example, to measure a length that is greater than 30 cm, a metre stick would be better than a ruler.

- .3s: *Students will analyze data and apply mathematical and conceptual models to develop and assess possible solutions*
- analyze graphs
  - infer mathematical relationships from empirical evidence
  - use free-body diagrams

The analysis of graphs, their shape as well as slope or area, is a skill foundational to scientific literacy. This includes, but is not limited to, relating graph shape to possible mathematical relationships and curve straightening, as well as using the slope, area, or intercept to bring physics meaning to the data. The variable that was manipulated in the experiment/investigation will be plotted on the x-axis; but for curve straightening, the variable on the x- or the y-axis, or both, may be manipulated.

Free-body diagrams consist of labelled arrows that point away from or toward a point that represents the centre of mass of the object on which forces act. Free-body diagrams should NEVER contain rectilinear components of the vectors.

The following graphic is often used on the diploma examination to show direction.



When using this graphic, students should select the direction that is aligned closest to the direction of the vector they are matching. It is not the intent of the examination to have directions limited to these 10.

.4s: *Students will work collaboratively in addressing problems and apply the skills and conventions of science in communicating information and ideas and in assessing results*

- use appropriate Système international (SI) units, fundamental and derived units and significant digits
- use appropriate numeric, symbolic, graphical, and linguistic modes of representation to communicate ideas, plans, and results
- use the delta notation correctly when describing changes in quantities

Although the examination cannot address working collaboratively, the clarity and consistency of communication can be assessed. This includes, but is not limited to, the algebra of unit analysis, using scientific notation and SI prefixes, and evaluating the quality of results of an investigation. The significance of limiting the number of digits in a measured (or calculated) value is based on the quality of the measurements made. **Note:** When recording answers for a numerical-response item, a calculated value of 0.25 has two significant digits but is considered a three-digit answer.

### Sign conventions

In the .2s part of the program, students are using vectors to show direction. In the .3s part of the program, students are using vector addition (graphically or algebraically) to determine a net vector. The .4s part of the program includes sign conventions as a quick and meaningful way of communicating information. The challenge inherent in quick methods is that they can be used ineffectively. Students should be able to explain the significance of the sign, positive (+) or negative (–), and why they are using it.

Examples of effective use of signs:

- Defining “down” as positive for a Physics 20 trajectory caused by an unbalanced gravitational force allows the use of  $+9.81 \text{ m/s}^2$  for the acceleration caused by gravity, which makes the calculator keystrokes easier
- Introducing a Cartesian plane into the solution of a two-dimensional interaction such that the signs on the x- and y-components make sense for an algebraic analysis
- Assigning + and – relative to a thin lens. It is immaterial which side is + and which is –.
- Correctly using delta notation for electric potential difference or mass defect such that the change in the final energy state of the system is consistent

Examples of ineffective use of signs:

- Misunderstanding what the negative sign in the magnification equation signifies
- Substituting the nature of charge into the electrostatics equations. It is much better to calculate the magnitude separately from the direction and then apply Newton’s third law to determine the directions

### Specific outcomes for STS

Each STS question will be assessed and reported on in one of two ways: “assesses an STS outcome” or “in an STS context.”

The diploma examination will present contexts in which students will be required to apply the understandings mandated in the **Specific Outcomes for Knowledge** and **Specific Outcomes for Skills**. When the context is an exact match to the description in the program of studies that is in regular font, then it is reported as “assesses an STS outcome.” When the context

does not exactly match the description in the program, it will be reported as “in an STS context.” The *italicized* examples in the program of studies are suggestions for when a teacher doesn’t have a better or a locally developed approach for applying the physics to the real-world experience of the students.

The relationship between the **Specific Outcomes for Science, Technology, and Society** and the philosophy of science education is addressed on page 10 of this document and in the Physics 20–30 Program of Studies under Foundation 3. There are three main areas: **Nature of Science (NS)**, **Science and Technology (ST)**, and **Social and Environmental Contexts (SEC)**. These are also used in the item description of the examination report.

### Specific outcomes for Knowledge

The actual cognitive load required of the students is often much greater than “knowledge – recall/ reproduce.” The *Physics 30 Diploma Examination* will assess the outcomes at any level up to, but not exceeding, the mandated cognition. The mark that a student receives on the diploma examination will reflect the cognition that the student, in general, is able to apply. The relationship between the student score and the cognition is described in the section titled “Cognitive Expectations in the Program of Studies.”

For a description of the relationship between the classroom mark and the cognition that the student may be using, in general, please see [Student-Based Performance Standards](#).

### General Outcome A: Momentum and Impulse

1. *Students will explain how momentum is conserved when objects interact in an isolated system.*

A1.1k, the definition and calculation of momentum, links to C2.6k, the momentum of a photon, and to D4.1k, the analysis of paths of unknown charged particles in external magnetic fields.

A1.3k expects students to apply the idea of systems. Defining what is inside the system (the objects and their interactions) is a necessary step before a valid analysis can be performed. The concept of “system” links to B2, B3, C2, D2, and D4.

An isolated system is one for which no external force does work on objects inside the system. As a result, only forces inside the system are significant. The analysis of this is based on Newton’s third law, which leads into conservation of momentum. Students should understand this logical progression.

In the real macro world, systems are usually non-isolated because external forces are often significant. Students should analyze the situations presented to them. They should not assume that the system is isolated or non-isolated.

A1.4k links to C2.6k and the analysis of Compton scattering.

A1.3s mandates two-dimensional analysis. For diploma questions, a well-drawn, scaled vector addition diagram will yield results good enough to answer questions. Students can calculate rectilinear components, but this is often a more time-intensive method. Students do not need to use sine or cosine laws, but if they have these skills, their use may save time. **Note:** These expectations also apply to B1.3s, B2.3s, and B3.3s.

### General Outcome B: Forces and Fields

1. *Students will explain the behaviour of electric charges, using the laws that govern electrical interactions.*
2. *Students will describe electrical phenomena, using the electric field theory.*
3. *Students will explain how the properties of electric and magnetic fields are applied in numerous devices.*

B1.3k, methods of charging, will usually use an electron-transfer model. This model is very good for describing the charging of metal objects. It is a weak model for describing what happens in charging by friction, where ion transfer is a much more likely mechanism. Students will NOT be tested on this subtlety.

B1.2sts links to B1.5k, in which students should be able to compare and contrast Coulomb’s torsion balance apparatus and experiment with those of Cavendish, as well as with B1.1s, experimental design, and with B1.3s, data analysis.

B1.8k allows the diploma examination to link electric forces to gravitational forces. This links to B2.3k, which relates electric potential difference to gravitational potential difference, as well as to B3.2k, which asks students to compare all three types

of fields in terms of sources and directions. Direction includes shape and the relationship between field line density and field strength.

B2.2k, comparing forces and fields, is becoming a very interesting outcome: The classical understanding of a field was to explain “action-at-a-distance” forces, which caused acceleration; the current understanding of a field is that the field is real. We describe fields using mathematics and infer a force based on the observed change in motion. These two approaches start in very different places and use different methods. Students should be familiar with the foundational philosophy that physics is about testing models against the real world, and where the models fail, the appropriate response is to either modify the model or devise a different test.

B2.8k and B2.3s link the linear and parabolic paths of charged particles in uniform electric fields to the identical analyses of objects moving in gravitational fields from Physics 20. The path of a charged object following a circular trajectory in a radial electric field is also an appropriate analysis for students. This links to D2.1k, the application of Maxwell’s theory to the evolution of the model of the atom.

B2.9k and B2.3s mandate the application of the physics principle of conservation of energy. This conservation principle shows up again in A1, B3, C2, D2, and D4. Conservation of energy requires students to define the system (the objects and their interactions) that they are analyzing. This should be done explicitly and at the start of the analysis. The mathematics follows from the definition.

B2.10k involves both a simplified analysis of cases where the oil drop is suspended, because then the frictional/buoyant forces are negligible, and a more complex analysis of cases where the motion is either uniform or accelerated. The quantum nature of charge is addressed in the program here, but there are also links to D1 and the evolution of the model of the atom.

B3.6k, B3.2s, and B3.3s mandate that students analyze situations in which forces are balanced and those in which forces are unbalanced.

B3.7k and B3.9k mandate that students be familiar with the phenomena of the “motor effect” and the “generator effect.” The principle of conservation of energy is a strong mechanism to explain the phenomena.

B3.2s mandates that students should be able to apply hand rules to determine the nature of the charge (sign), the direction of charge motion, the direction of conductor motion, the direction of the force acting on the charge, the direction of the force acting on the conductor, the direction of the external magnetic field, and the direction of the induced magnetic field. The diploma examination will use the word *current* when the nature of the moving charge doesn’t matter and will specify the nature of the charge when it does.

## General Outcome C: Electromagnetic Radiation

1. *Students will explain the nature and behaviour of EMR, using the wave model.*
2. *Students will explain the photoelectric effect, using the quantum model.*

C1.4k and C1.1s mandate that students should devise or analyze an experimental design to determine the speed of light. This relates as well to C1.4s and evaluating the quality of the results. This outcome is not limited to historical experiments.

C1.6k and C1.11k are significant in helping students understand the process of having a model that can be used to describe or explain observations that, when the observations don’t match the description, result in a necessary change to the model or in new experiments. C1.6k deals with the change in direction without specifying a mechanism. C1.11k deals with using wave-related observations to explain observations associated with refraction.

To reinforce this difference, the two equations are separate in the Equations section of the Physics 30 Data Sheets found on the [Writing diploma exams](#) web page.

C1.7k requires mindful use of words by students and teachers: Lenses are described by the effect that they have on light rays, and mirrors are described in terms of the shape of the reflective surface. This helps students who might pursue a career in optics to avoid learning incorrect descriptions of lenses and mirrors. The outcome builds on the ray diagram skills from Science 8, so questions on the diploma examination will require the interpretation of a ray diagram rather than just the creation of a ray diagram.

C1.8k requires that students understand the perpendicular field components of EMR. Students should be familiar with the terms *transverse* and *longitudinal*.

C1.10k is another example of model testing and revising. This outcome relates to the small angle theorem, which links to C1.6k and Physics 20 pendulum analysis. When this outcome is done well, students become more confident in understanding that models have strengths while also necessarily having limitations.

C1.2s is the section of the program with the longest list of mandated measurement situations. This part of the program is an excellent place to ensure that students have explored their full experimental skills because the equipment can be inexpensive and the risk of student harm is low. The diploma examination may require students to make measurements of angles or distances on diagrams. Students should bring a protractor and a ruler to the examination writing. If they forget, a ruler is printed on the tear-out pages for them to use. This ruler is sufficient for the requirements of the examination. Students should be making the largest possible measurements given the equipment they are using to minimize the inherent error of estimating the last digit. Significant digits and the evaluation of the quality of observations should be based on the measurements students make.

C2.3k should build on Physics 20 mechanical waves and C1. This is another example of models failing to provide descriptions that match observations. Students should be able to build a prediction based on a classical-mechanical or an electromagnetic wave model. They should be able to articulate why the observations associated with the photoelectric effect are NOT consistent with either model and then describe how the model of light being composed of photons provides a description that matches observations.

C2.4k requires an early-1900s understanding of the photoelectric effect consistent with Einstein's explanation that 1 photon = 1 electron and intensity (brightness) is a measure of the number of photons. Recent advancements in technology show that this model is insufficient, but current models are beyond the Physics 20–30 Program of Studies, 2007 (Updated 2014).

C2.6k links to A1.4k, A1.5k, and A1.1k. Students should be able to analyze a simple Compton event in terms of conservation of momentum or conservation of energy. The diploma examination will not require a full mathematical analysis using both conservation principles.

Also, the program mandates that students calculate the momentum of a photon. The converse, the associated wavelength of a moving particle, can be tested on the diploma examination using items that tell the students how to apply the de Broglie relationship.

C2.1sts relates the historical work of scientists to changing experiments (Hertz) and changing models (Planck).

## General Outcome D: Atomic Physics

1. *Students will describe the electrical nature of the atom.*
2. *Students will describe the quantization of energy in atoms and nuclei.*
3. *Students will describe nuclear fission and fusion as powerful energy sources in nature.*
4. *Students will describe the ongoing development of models of the structure of matter.*

D1 is a wonderful place to really explore the reciprocity between theoretical advances and technological advances. When this unit is done well, students have a deep understanding of the relationship between observations and the characteristics of models that developed in response to the observations; they also understand that every model has its limitations. This links directly to D2.1k, which relates the theory from the mid-1800s to the model proposed in the late-1800s.

D3.1k requires students to understand that biological damage is caused when radiation (alpha, beta-negative, or gamma) deposits its energy in living tissue.

- Students should be able to link B1.2k, electrical interactions, to the nature and size of charge on the three types of radiation: alpha particles will interact more strongly, and then beta-negative particles, while gamma interactions are NOT described by a Coulomb model. Electrically charged radiation deposits energy continuously, but not uniformly, as the radiation travels through biological tissue.
  - Beta-negative particles are much less massive than alpha particles and are more easily scattered during interactions with atomic nuclei; so their paths through materials are much less direct than those of alpha particles.
  - Beta-positive particles are much less massive than alpha particles and are more easily scattered. However, at low energies, they interact with electrons, causing annihilation. This releases gamma radiation and changes the chemistry in their immediate location only.

- Alpha particles ionize virtually every molecule they pass, creating between 4000 and 9000 ion pairs per micrometre of tissue. Beta-negative particles ionize only about 1 in 1000 molecules encountered and create only six to eight ion pairs per micrometre of tissue.
- The rate of ionization for an alpha particle increases as the particle slows and peaks just before the alpha particle stops. Most of the energy released is within a very small volume of space compared to that for a beta-negative particle.
- Students should be able to apply ideas from C2.1k, photon energy; C2.3k, work function, or D2.4k, electron energy levels; C2.6k, the Compton effect; and D3.1sts, pair production, to describe/predict how gamma radiation interacts with biological tissues:
  - Energy below a threshold (the energy required to free an electron, the energy required to break a molecular bond) will not produce any effect on the photon, so it will penetrate the tissue and cause no damage.
  - Energy high enough to free an electron (photoelectric effect) will result in the photon disappearing, the production of a free low-energy electron, and an ion. This affects the chemistry in the living tissue and is the most probable interaction.
  - Energy high enough to break molecular bonds will result in the photon disappearing but also the production of ions, which affect the chemistry in the living tissues.
  - Energy high enough to cause Compton scattering results in lower but still high-energy photons, high-energy electrons, and ions whose associated damage is described above.
  - Energy high enough to cause pair production results in the photon disappearing and the production of new charged particles where a positron–electron annihilation occurs fairly quickly, producing high-energy photons.
- The effects of the various types of damage are different, too.
  - Referring specifically to the ionization effect on living matter, there are several main concerns: production of free radicals from water, which may recombine to form peroxide ( $\text{H}_2\text{O}_2$ ) that initiates harmful chemical reactions in cells and tissues; breaking bonds within macromolecules, destroying their functioning; and damage to DNA molecules (self-repairing but now with transcription errors (mutations) built in).

“Highly interactive” means not highly penetrating. In other words, a gamma photon is highly penetrating and is not likely to interact; a beta-negative particle has less penetrating ability in living tissue, so it is more likely to interact. The gamma photon will likely be absorbed and cause changes to the chemistry near the absorption site, whereas the beta-negative particle will experience a small reduction in energy each time it is scattered. Its interactions also change the chemistry near each scattering site.

A widely held misconception is that radiation is always dangerous and that the higher the energy is, the more dangerous the radiation is. A more solid analysis includes the energy, charge, mass, and number of radiation particles to evaluate the likelihood and nature of damage.

D3.2s requires the analysis of a graph to determine half-life. Students should be using more than one value from the curve in determining the half-life. The diploma examination will not use semi-log paper.

D3.6k links to D3.1k, properties of beta particles, to D3.2k, beta-positive and beta-negative particles and their neutrino partners, and to D3.1sts, permitting the assessment of annihilation reactions. The information on the data sheets can make these calculations more like recall. Students should also know the terms *electron* and *positron* as matter–antimatter partners.

D3.2sts, assessing risk, D3.1k, biological effects, and D3.4s, communication and units, combine to allow for a rich discussion with students about the multitude of units for measuring and reporting the rate and significance of radiation; e.g., number of counts, becquerel, currie, rad, rem, grey, and sievert.

D4.1k is related to, but goes beyond, B3.2s. If students already know what the particles are, then the task is reported as B3.2s. If the students need to determine characteristics of unknown particles, then the task is reported as D4.1s or D4.3s.

D4.2k requires the students to know that the net strong nuclear interaction is a repelling force at distances less than  $10^{-16}$  m, very strong attractive force at a range of  $10^{-15}$  m, and insignificant at distances greater than  $10^{-15}$  m. This links to D1.4k and the description of the atom based on the alpha-particle-scattering experiments. This also links to B1.6k or B1.7k, which involve the analysis of one or more charged objects near each other.

D4.3k specifies which standard model is being used to describe protons and neutrons. This is another area where the general concept of a model being only as good as what it can be used to explain is significant. There are observations with which the standard model is consistent, and there are others with which it does not agree. Students should not be memorizing truths.

---

## Publications and Supporting Documents

In addition to this Information Bulletin, the following documents are published by Alberta Education and Childcare and are available on the [Writing diploma exams](#) web page:

- *Physics 30 Archived Bulletin*
- *Physics 30 Student-Based Performance Standards*
- *Physics 30 Released Items*
- *Examples of Descriptions Used in Audio Versions of Science Diploma Exams*
- *2025–2026 Calculator Information and Rules for Mathematics and Science Diploma Exams*
- *A Guide for Students Preparing to Write the Diploma Examination:  
Biology 30 / Chemistry 30 / Physics 30 / Science 30*

---

## Website Links

[Alberta Education and Childcare](#) website

[Programs of study](#)

[General Information Bulletin](#)

contains specific directives, guidelines, and procedures of diploma examinations

[Diploma exams](#)

[Writing diploma exams](#)

contains Guides for Students, exemplars, and other support documents

[Quest A+](#)

contains practice questions and questions from previous diploma examinations

[Digital Assessment Platform](#)

contains practice questions and questions from previous diploma examinations

**\*NEW** [Help page](#)

contains guides to help users of digital assessments access and administer secured tests and exams

[Field Test Information](#)

[Teacher participation in provincial assessments](#)

contains information about marking, field testing, item development, and examination validation

[School Reports and Instructional Group Reports](#)

contain detailed statistical information on provincial, group, and individual student performance on the entire examination

# Contacts 2025–2026

## Provincial Assessment

Provincial Assessment,  
Alberta Education and Childcare  
44 Capital Boulevard  
10044 108 Street NW  
Edmonton AB T5J 5E6

Alberta Education and Childcare website: [alberta.ca/education-and-childcare](https://alberta.ca/education-and-childcare)

## Provincial Assessment

### Diploma exam security, diploma exam rules, scheduling, and policy issues

780-427-1857

Email: [exam.admin@gov.ab.ca](mailto:exam.admin@gov.ab.ca)

### Results statements and rescores

780-427-1857

Email: [exam.admin@gov.ab.ca](mailto:exam.admin@gov.ab.ca)

### Special cases, accommodations, and exemptions

780-415-9242

780-427-4215

780-427-9795

Email: [special.cases@gov.ab.ca](mailto:special.cases@gov.ab.ca)

### Field testing

Email: [field.test@gov.ab.ca](mailto:field.test@gov.ab.ca)

### Diploma exam format, content, confirming standards, marking, and results reporting

Email: [diploma.exams@gov.ab.ca](mailto:diploma.exams@gov.ab.ca)

### French Assessment

Email: [french.assessment@gov.ab.ca](mailto:french.assessment@gov.ab.ca)

### Digital Assessment

780-641-8987

780-415-0824

Email: [online.assessment@gov.ab.ca](mailto:online.assessment@gov.ab.ca)

### myPass Access

#### Alberta Education and Childcare Help Desk

780-427-5318

Email: [AE.helpdesk@gov.ab.ca](mailto:AE.helpdesk@gov.ab.ca)

### Inquiries about transcripts, credentials, detailed academic reports, and rewrite fees

780-427-5732

Email: [studentrecords@gov.ab.ca](mailto:studentrecords@gov.ab.ca)

### Inquiries about student enrollment and marks and mature student status

780-422-9337

Email: [studentrecords@gov.ab.ca](mailto:studentrecords@gov.ab.ca)

### Packing and shipping of test materials

780-427-1857

Email: [exam.admin@gov.ab.ca](mailto:exam.admin@gov.ab.ca)

For a toll-free call to any Alberta government office, dial 310-0000 followed by the 10-digit phone number of the office that you would like to reach.

When contacting Alberta Education and Childcare, please include your name, title, school name, school code, and, if referring to a student, include the student's Alberta Student Number.

# Contacts 2025–2026

## Diploma Programs

**\*NEW**

### **Terri Lynn Mundorf, Director**

Diploma Programs  
780-422-0206  
Email: [Terri-Lynn.Mundorf@gov.ab.ca](mailto:Terri-Lynn.Mundorf@gov.ab.ca)

## **French Assessment and Canadian Adult Education Credential**

### **Corey Baker, Director**

French Assessment and Canadian Adult Education Credential  
780-422-3256  
Email: [Corey.Baker@gov.ab.ca](mailto:Corey.Baker@gov.ab.ca)

## Diploma Exam Leads

### **Nathalie Langstaedtler, Senior Manager of Humanities**

Diploma Programs  
780-422-4631  
Email: [Nathalie.Langstaedtler@gov.ab.ca](mailto:Nathalie.Langstaedtler@gov.ab.ca)

### **Philip Taranger**

English Language Arts 30–1  
780-422-4478  
Email: [Philip.Taranger@gov.ab.ca](mailto:Philip.Taranger@gov.ab.ca)

### **Keri Helgren**

English Language Arts 30–2  
780-422-5213  
Email: [Keri.Helgren@gov.ab.ca](mailto:Keri.Helgren@gov.ab.ca)

### **Charla Jo Guillaume**

Social Studies 30–1  
780-422-5241  
Email: [Charlajo.Guillaume@gov.ab.ca](mailto:Charlajo.Guillaume@gov.ab.ca)

### **Lisa Lemoine**

Social Studies 30–2  
780-422-4327  
Email: [Lisa.Lemoine@gov.ab.ca](mailto:Lisa.Lemoine@gov.ab.ca)

### **Gwendolyn Shone, Manager of French Assessment**

French Assessment and Canadian Adult Education Credential  
780-422-5464  
Email: [Gwendolyn.Shone@gov.ab.ca](mailto:Gwendolyn.Shone@gov.ab.ca)

### **Frédéric Sévigny**

Français 30–1, French Language Arts 30–1  
780-422-5140  
Email: [Frederic.Sevigny@gov.ab.ca](mailto:Frederic.Sevigny@gov.ab.ca)

### **Joy Wicks, Senior Manager of Math and Sciences**

Diploma Programs  
780-643-6716  
Email: [Joy.Wicks@gov.ab.ca](mailto:Joy.Wicks@gov.ab.ca)

### **Shannon Mitchell**

Biology 30  
780-415-6122  
Email: [Shannon.Mitchell@gov.ab.ca](mailto:Shannon.Mitchell@gov.ab.ca)

### **Brenda Elder**

Chemistry 30  
780-427-1573  
Email: [Brenda.Elder@gov.ab.ca](mailto:Brenda.Elder@gov.ab.ca)

### **Delcy Rolheiser**

Mathematics 30–1  
780-415-6181  
Email: [Delcy.Rolheiser@gov.ab.ca](mailto:Delcy.Rolheiser@gov.ab.ca)

### **Jenny Kim**

Mathematics 30–2  
780-415-6127  
Email: [Jenny.Kim@gov.ab.ca](mailto:Jenny.Kim@gov.ab.ca)

### **Marc Kozak**

Physics 30  
780-422-5465  
Email: [Marc.Kozak@gov.ab.ca](mailto:Marc.Kozak@gov.ab.ca)

### **Stan Bissell**

Science 30  
780-422-5730  
Email: [Stan.Bissell@gov.ab.ca](mailto:Stan.Bissell@gov.ab.ca)